

Quality First & Customer's Satisfaction

ROBONICDRIVE

諧波減速機

2



DSF 23



DHF 33

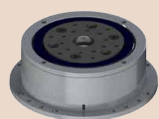

DSS 43

CYKODRIVE

高精度擺線減速機

45



RSE 49

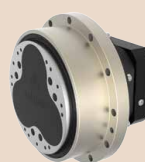

RSN 57



RDN 65



RCN 73

DSF



諧波產生器
Wave Generator

薄壁軸承
Elastic Bearing

杯型柔性齒輪
Cup-Type Flex Gear

剛性內齒輪
Internal Gear

DHF

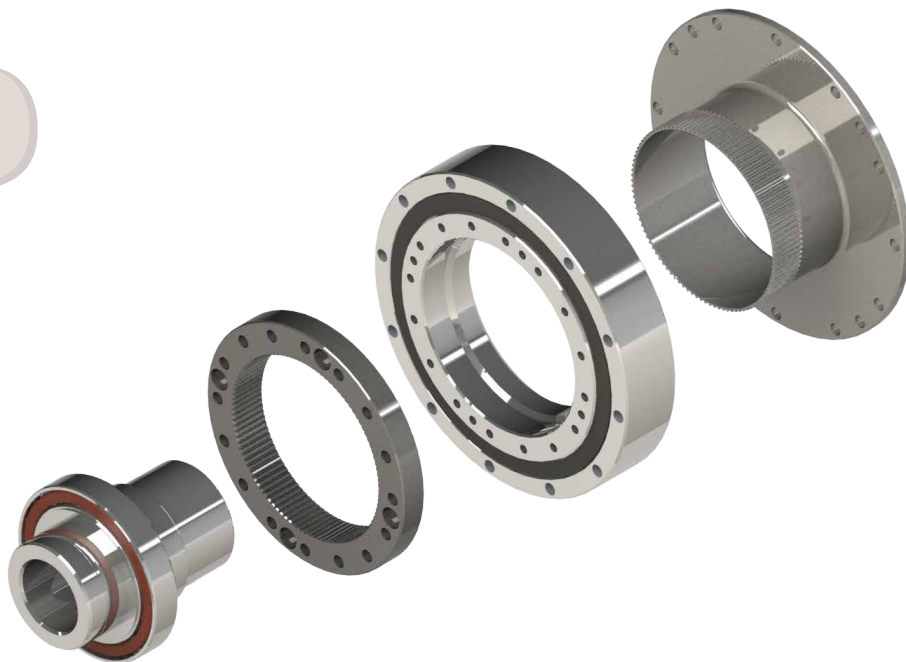

諧波產生器
Wave
Generator

薄壁軸承
Elastic
Bearing

剛性內齒輪
Internal
Gear

交叉圓柱滾子軸承
Crossed Roller
Bearing

帽型柔性齒輪
Hat-Type
Flex Gear

ROBONICDRIVE

諧波減速機

減速機構 Reduction Mechanism

- 通過凸輪使薄壁軸承、柔性齒輪呈橢圓狀變形。
- 柔性齒輪與內齒輪在橢圓形長軸部分發生嚙合。
- 固定內齒輪，使凸輪沿順時針方向旋轉 360°時，柔性齒輪會沿逆時針方向移動內齒輪與柔性齒輪的齒數差部分。

- Flex gear and elastic bearing take elliptic shape with the wave generator inserted.
- Flex gear and internal gear are engaged at both ends of the long axis of the ellipse in a stable manner.
- With the internal gear fixed, when the wave generator is rotated clockwise, the flex gear (output) rotates counterclockwise. And its rotational speed is determined by the tooth count differential between two gears.

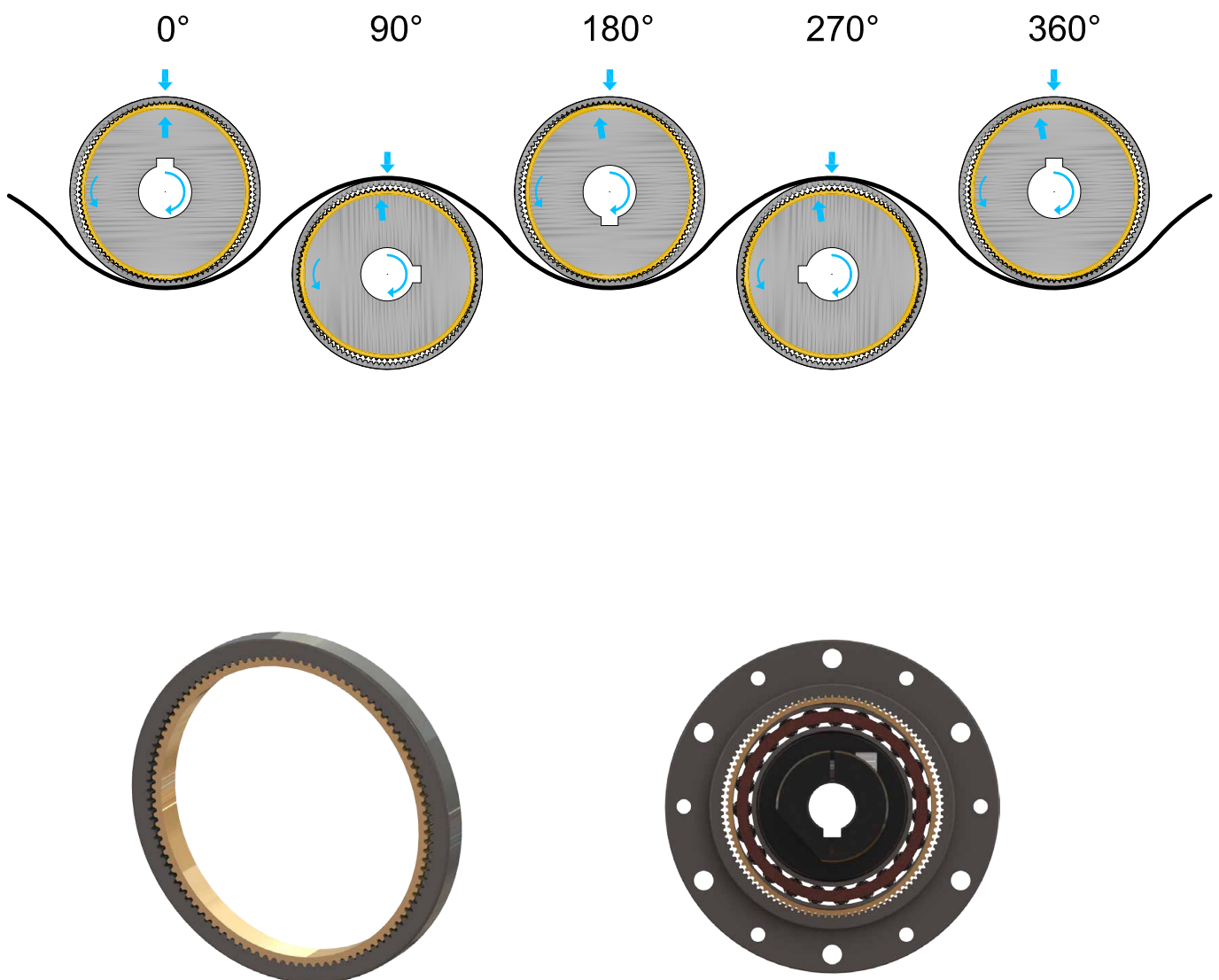

零件名稱 Parts Name

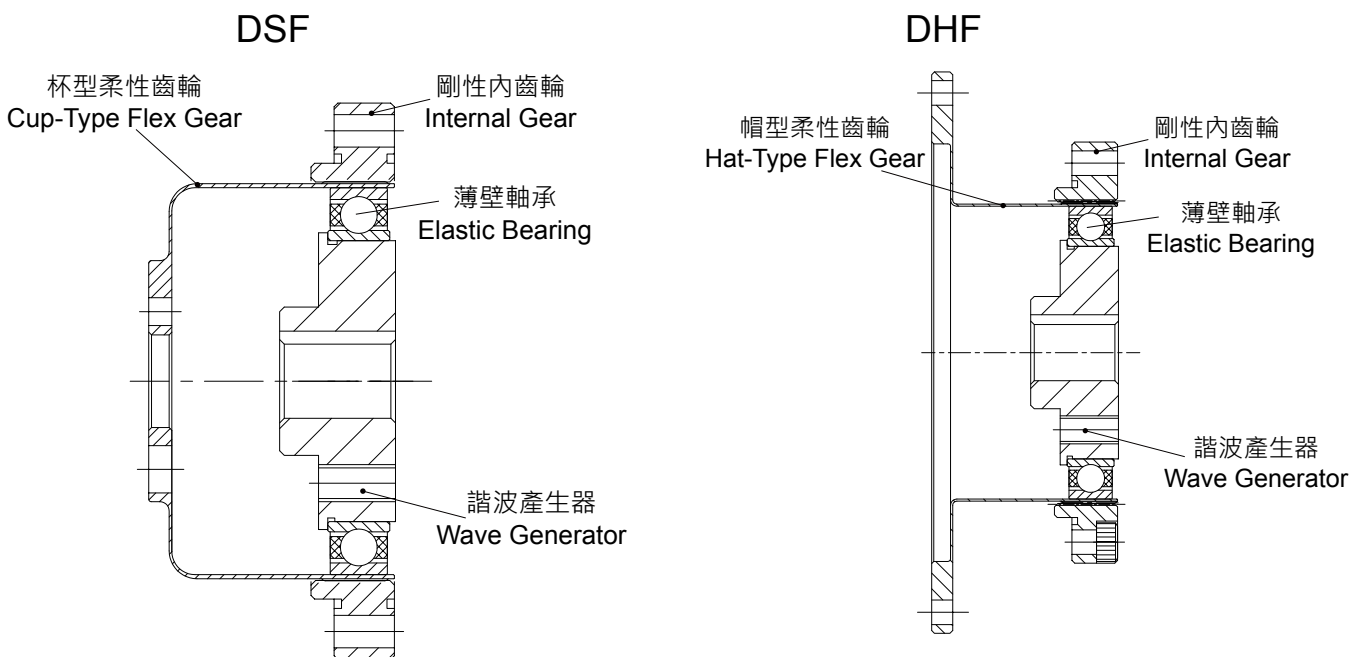

減速比 Ratio

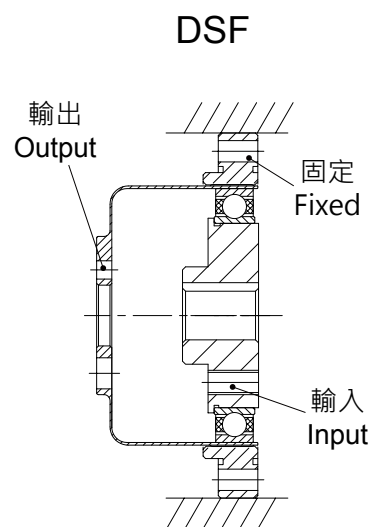

減速比由杯型柔性齒輪和剛性內齒輪來決定

杯型柔性齒輪齒數 Flex Gear : Z_f
剛性內齒輪齒數 Internal Gear : Z_c

$$\text{減速比 Ratio} = \frac{-1}{R} = \frac{Z_f - Z_c}{Z_f}$$

$$\text{減速比 Ratio} = \frac{1}{R}$$

※ 輸入旋轉方向與輸出旋轉方向相反
The input and output rotation directions are opposite.

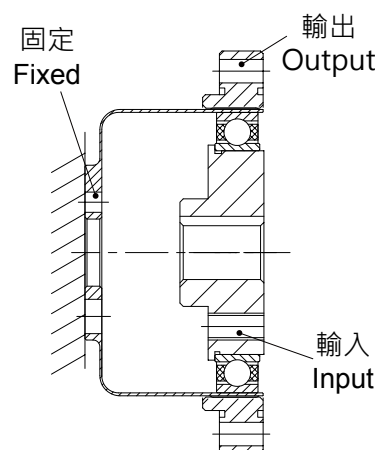

$$\text{減速比 Ratio} = \frac{1}{R+1}$$

※ 輸入旋轉方向與輸出旋轉方向相同
The input and output rotation directions are same.

● R 為減速機規格表中的減速比
R represents the "Ratio" figure in the specifications table on the next page.

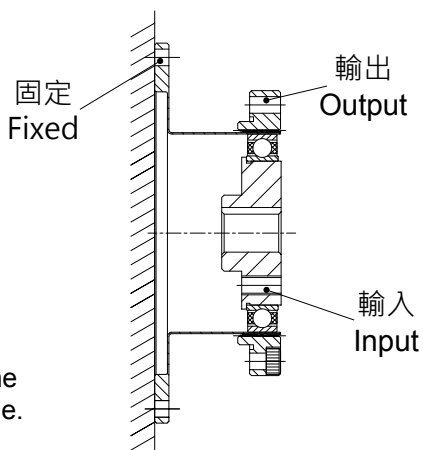
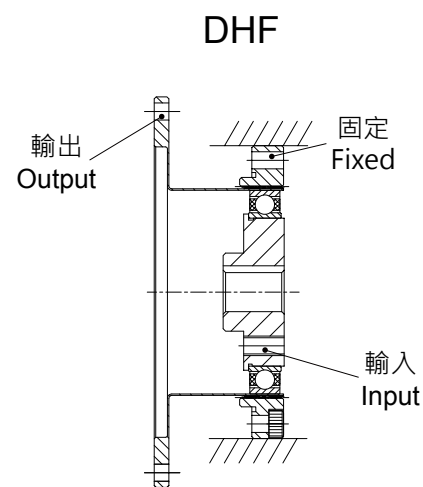

潤滑劑 Lubricant Information

潤滑劑的使用 Lubrication

全合成潤滑油脂
Synthetic grease No.2.

unit: g

型號 Model	DSF / DHF			
	A	B	C	D
14	1	3	0.25	0.5
17	2	6	0.5	1
20	3	9	0.75	1.5
25	6	18	1.5	3
32	12	36	3	6
40	22	66	5.5	11
45	34	102	8.5	17

潤滑劑的塗抹 Grease Application

DSF 及 DHF 按照右表要求塗抹潤滑劑。
For DSF and DHF, please apply grease according to the right table.

潤滑劑的塗抹部位 Grease Application Location

DSF-PC
DSF-PK

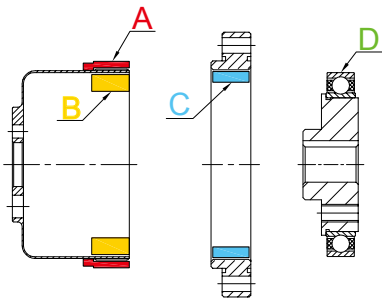

DSF-AC
DSF-AK

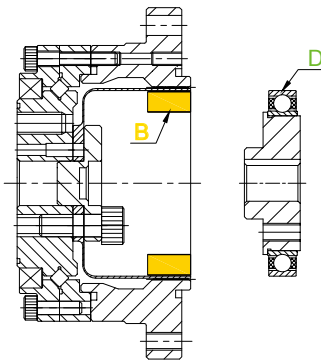

DHF-AC
DHF-AK
DHF-AO

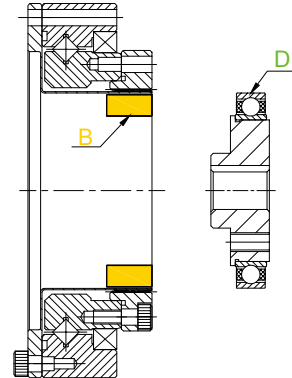

E 處填充量為空間的 50% 油量

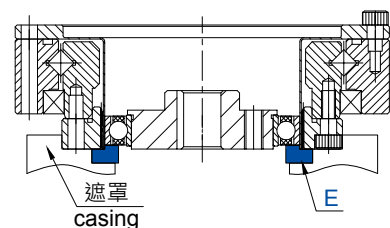
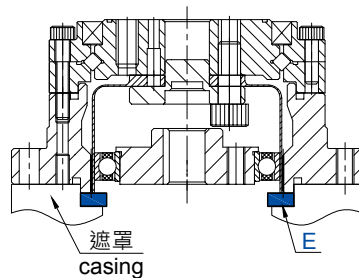
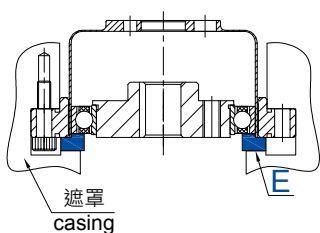
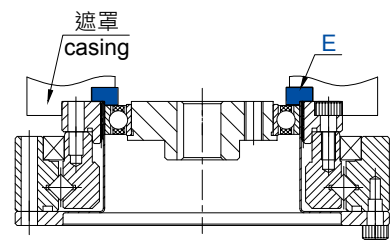
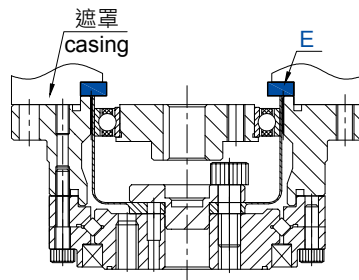
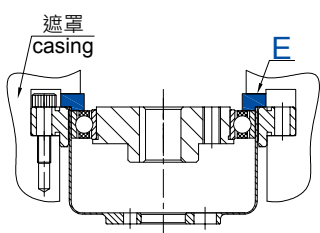

安裝精度 Attachment Fixture Requirement

DSF-PK

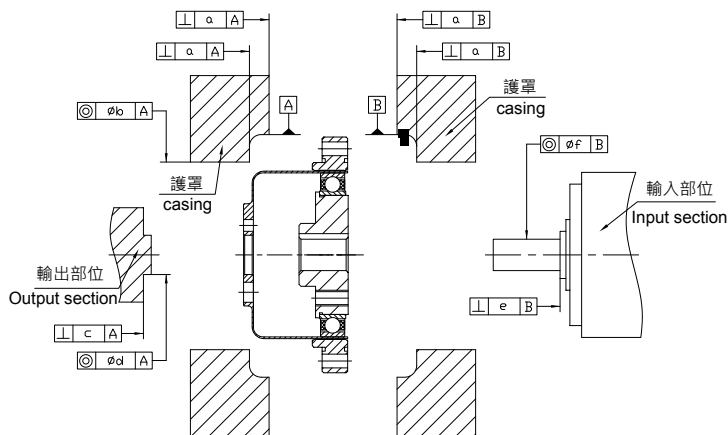

unit: mm

型號 Model	14	17	20	25	32	40
a	0.015	0.015	0.018	0.018	0.023	0.023
b	0.016	0.020	0.020	0.024	0.024	0.024
c	0.010	0.012	0.014	0.016	0.020	0.020
d	0.013	0.013	0.015	0.018	0.020	0.020
e	0.012	0.012	0.014	0.016	0.016	0.020
f	0.016	0.020	0.024	0.024	0.024	0.024

DSF-AK

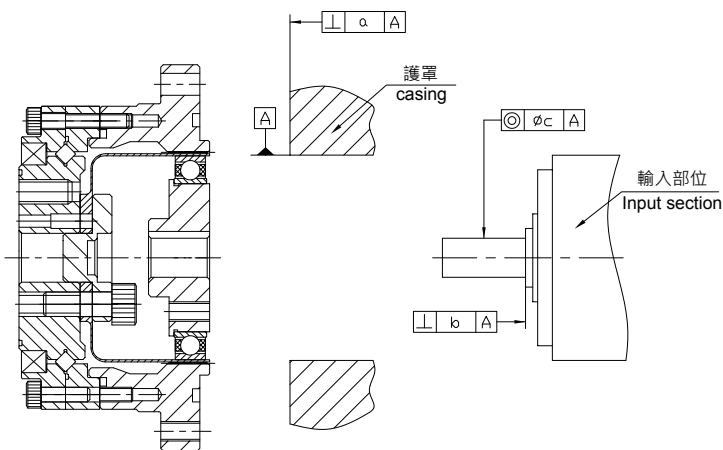

unit: mm

型號 Model	14	17	20	25	32	40
a	0.020	0.020	0.020	0.025	0.025	0.025
b	0.012	0.012	0.014	0.016	0.016	0.016
c	0.016	0.020	0.024	0.024	0.024	0.024

DHF-AK

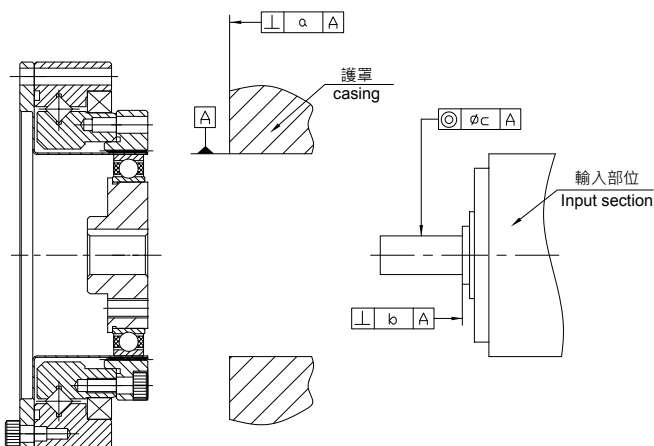

unit: mm

型號 Model	14	17	20	25	32	40	45
a	0.020	0.020	0.020	0.025	0.025	0.025	0.025
b	0.012	0.012	0.014	0.016	0.016	0.016	0.016
c	0.016	0.020	0.024	0.024	0.024	0.024	0.024

傳導力矩 Transmitting Torque

螺絲緊固力矩 Tightening Torque for Bolts

unit: Nm

螺絲 Bolts	M3	M4	M5	M6	M8	M10
螺絲緊固力矩 Tightening Torque	1.9	4.3	8.7	15	36	71

推建議螺絲：強度區分 12.9 以上

Recommended bolt : Strength rating above 12.9

傳導力矩 Bolt Specifications and Transmitting Torque

DSF-AC、DSF-AK (組合式 Unit Type)

安裝輸出法蘭 Output flange Attachment

型號 Model	Unit	14	17	20	25	32	40
螺絲 Bolt		M4	M5	M6	M8	M10	M10
螺絲個數 Bolt Count		6	6	8	8	8	8
安裝 PCD Bolt PCD	mm	23	27	32	42	55	68
緊固力矩 Tightening Torque	Nm	4.3	8.7	15	36	71	71
傳導力矩 Transmitting Torque	Nm	56	106	238	566	1,177	1,177

安裝內齒輪 Internal Gear Attachment

型號 Model	Unit	14	17	20	25	32	40
螺絲 Bolt		M4	M4	M5	M5	M6	M8
螺絲個數 Bolt Count		6	6	6	8	8	8
安裝 PCD Bolt PCD	mm	65	71	82	96	125	144
緊固力矩 Tightening Torque	Nm	4.3	4.3	8.7	8.7	15	36
傳導力矩 Transmitting Torque	Nm	158	172	322	503	1,392	4,150

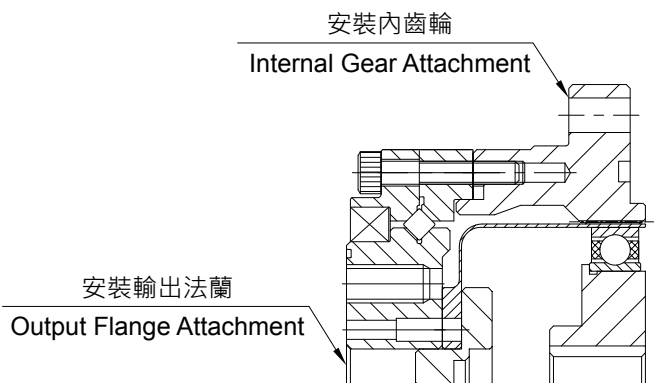

傳導力矩 Bolt Specifications and Transmitting Torque

DSF-PC、DSF-PK (組件式 Component Type)

安裝杯型柔性齒輪 Cup-Type Flex Gear Attachment

型號 Model	Unit	14	17	20	25	32	40
螺絲 Bolt		M4	M5	M5	M6	M8	M10
螺絲個數 Bolt Count		6	6	8	8	8	8
安裝 PCD Bolt PCD	mm	17	19	24	30	40	50
緊固力矩 Tightening Torque	Nm	4.3	8.7	8.7	15	36	71
傳導力矩 Transmitting Torque	Nm	41	75	126	223	539	910

安裝內齒輪 Internal Gear Attachment

型號 Model	Unit	14	17	20	25	32	40
螺絲 Bolt		M3	M3	M3	M4	M5	M6
螺絲個數 Bolt Count		8	16	16	16	16	16
安裝 PCD Bolt PCD	mm	44	54	62	77	100	122
緊固力矩 Tightening Torque	Nm	1.9	1.9	1.9	4.3	8.7	15
傳導力矩 Transmitting Torque	Nm	82	200	230	485	1,048	1,800

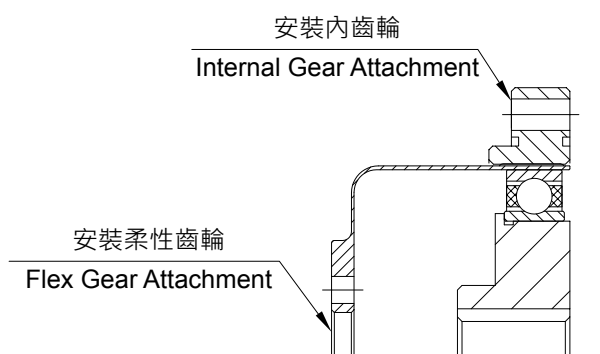

銷子孔的追加 Reinforcement

柔性齒輪安裝的傳導力矩未滿足要求時，請同時使用銷子。
銷子孔可根據需求追加。

Pins can be added if the transmittable torque at the flex gear interface is not sufficient.
As an option, holes can be added.

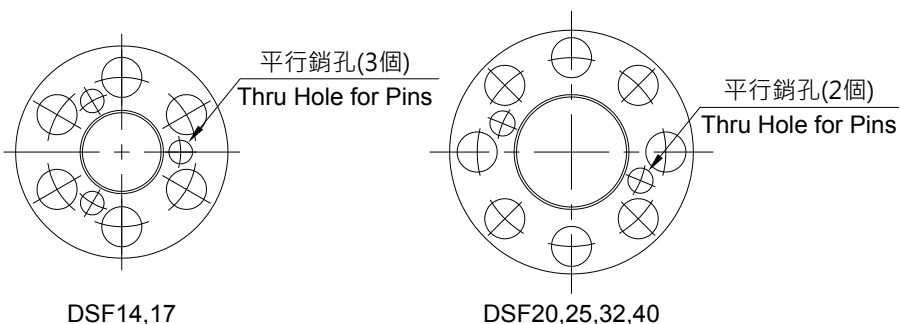

傳導力矩 Bolt Specifications and Transmitting Torque

DHF

安裝帽型柔性齒輪 Hat-Type Flex Gear Attachment

型號 Model	Unit	14	17	20	25	32	40	45
螺絲 Bolt		M3	M3	M3	M4	M5	M6	M6
螺絲個數 Bolt Count		8	12	12	12	12	12	18
安裝 PCD Bolt PCD	mm	64	74	84	102	132	158	180
緊固力矩 Tightening Torque	Nm	1.9	1.9	1.9	4.3	8.7	15	15
傳導力矩 Transmitting Torque	Nm	119	206	234	495	1,037	1,392	2,088

安裝內齒輪 Internal Gear Attachment

型號 Model	Unit	14	17	20	25	32	40	45
螺絲 Bolt		M3	M3	M3	M4	M5	M6	M8
螺絲個數 Bolt Count		8	16	16	16	16	16	12
安裝 PCD Bolt PCD	mm	44	54	62	77	100	122	140
緊固力矩 Tightening Torque	Nm	1.9	1.9	1.9	4.3	8.7	15	36
傳導力矩 Transmitting Torque	Nm	82	200	230	485	1,048	1,258	2,680

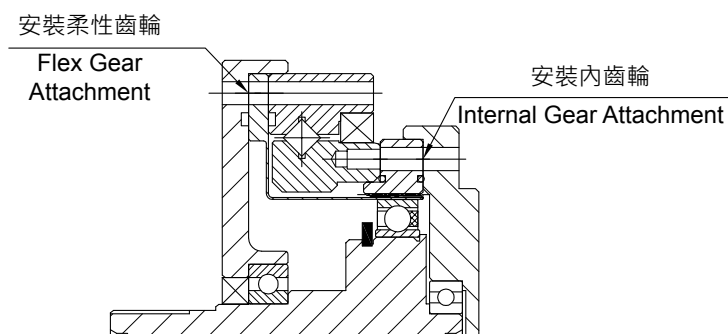
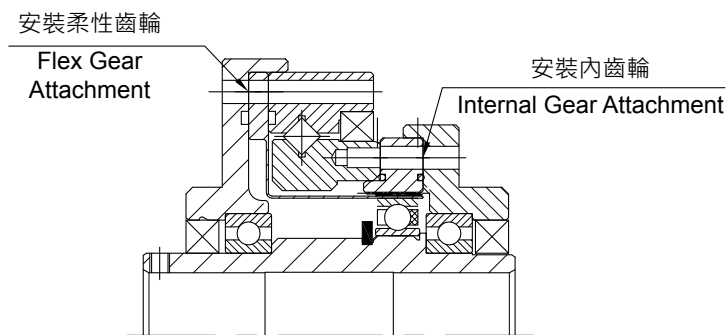
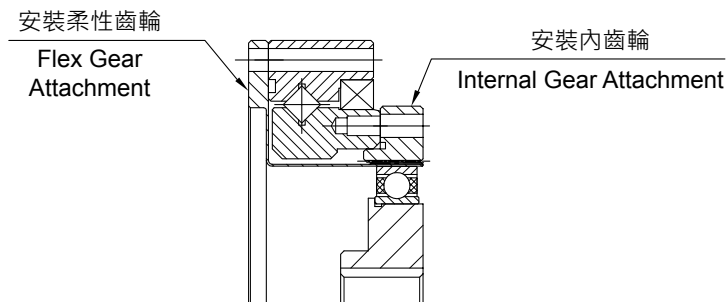

輸入部位構造 Input Section Structure

輸入部位構造 Input Section Structure

輸入部位構造分為鍵槽型與迫緊型，因輸入孔徑等差異而不同。

There are two types of input section structure, keyway and collet + keyway.

鍵槽型

Keyway Type

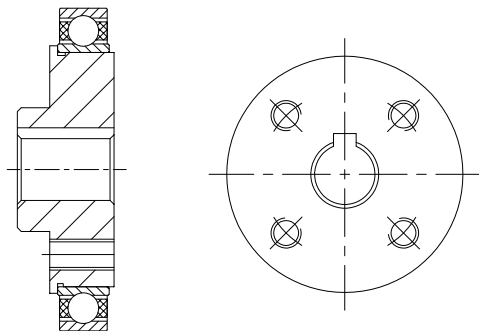

迫緊型

Collet + Keyway

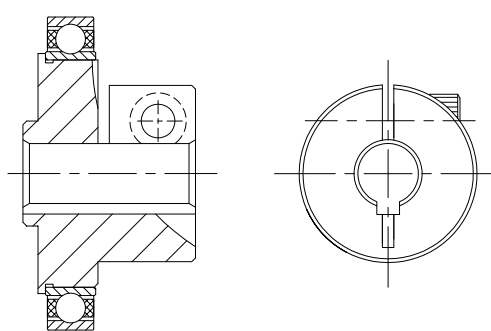

入力孔徑尺寸 Input Hole Diameter

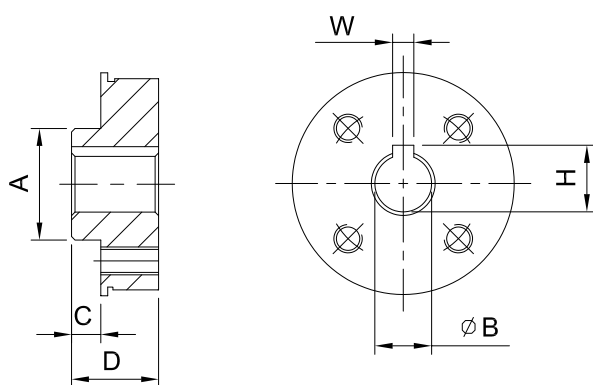

入力鍵槽尺寸 Input Bore Dimension

unit: mm

型號 Model	14	17	20	25	32	40	45
入力孔徑 Input Bore B	6、8	8	8、14	14	14、19	19、24	19、24
鍵槽寬 W	2、3	3	3、5	5	5、6	6、8	6、8
鍵高 H	7、9.4	9.4	9.4、16.3	16.3	16.3、21.8	21.8、27.3	21.8、27.3
螺絲	2-M4	2-M4	4-M4	4-M5	4-M5	4-M5、4-M6	4-M6
安裝 PCD	18	22	25	32	36	50	50
A	14	16	20	22	30	32.33	32.34
C	2.3	4.2	4.3	6	5	7	5
D	10	12.5	13.5	14.5	16	20	20

馬達安裝方法 Motor Mounting Instructions

安裝方式 Installation Method 1

- 步驟 1：將法蘭安裝至馬達上
 步驟 2：將諧波產生器安裝至馬達軸上
 步驟 3：安裝至組合型產品元件
 step 1: Attach the flange on to the motor.
 step 2: Attach the wave generator on to the motor shaft.
 step 3: Attach the unit.

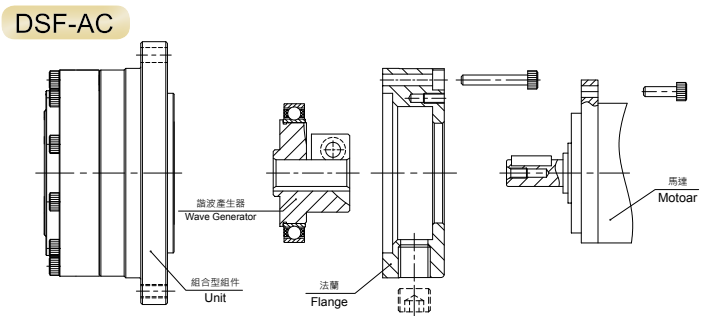
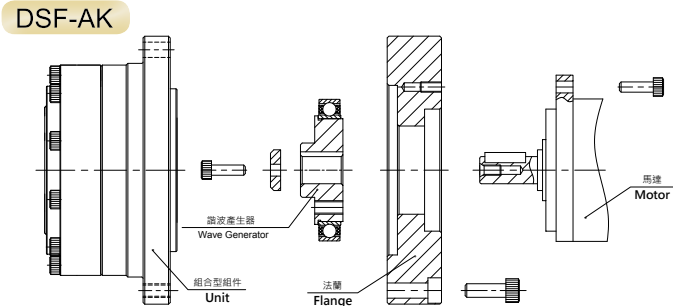

安裝方式 Installation Method 2

- 步驟 1：將諧波產生器安裝至馬達軸上
 步驟 2：將法蘭安裝至馬達上
 步驟 3：安裝至組合型產品元件
 step 1: Attach the wave generator on to the motor shaft.
 step 2: Attach the flange on to the motor.
 step 3: Attach the unit.

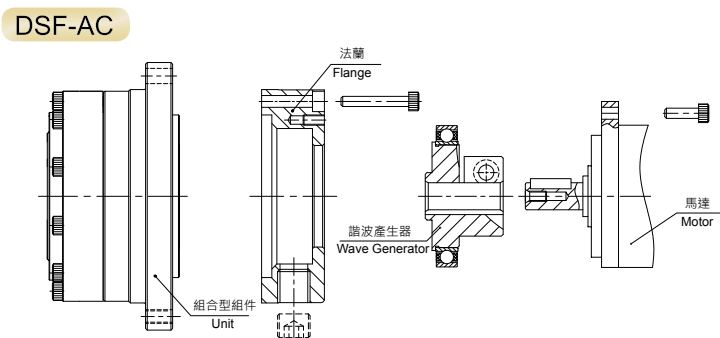
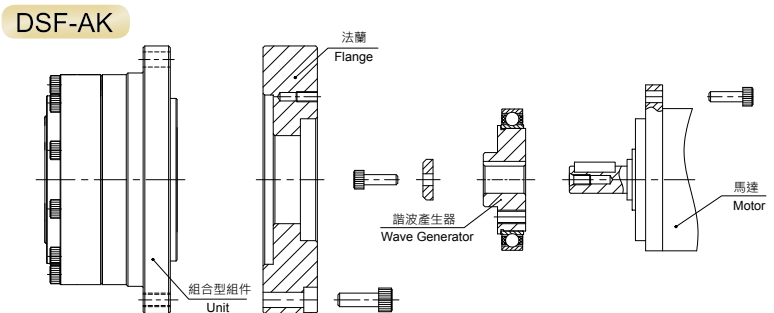

安裝操作時的注意事項 Caution during installation

- 組裝各零部件時，不可過度用力頂壓。
- 注意不可傾斜插入諧波產生器。
- Do not use excessive force while mating parts.
- Please watch for tilting during input section assembly wave generator.

注意事項 Installation and Assembly Instructions

入力軸 / 出力軸的支撐 (DSF) Shaft Installation Instruction

入力軸 / 出力軸請採用承受作用於軸部的徑向負荷 / 軸向負荷的支撐構造。(下圖為參考實例)
Please design the support structure for input shaft and output shaft so that both radial and axial loads are supported. (Diagram below shows an example)

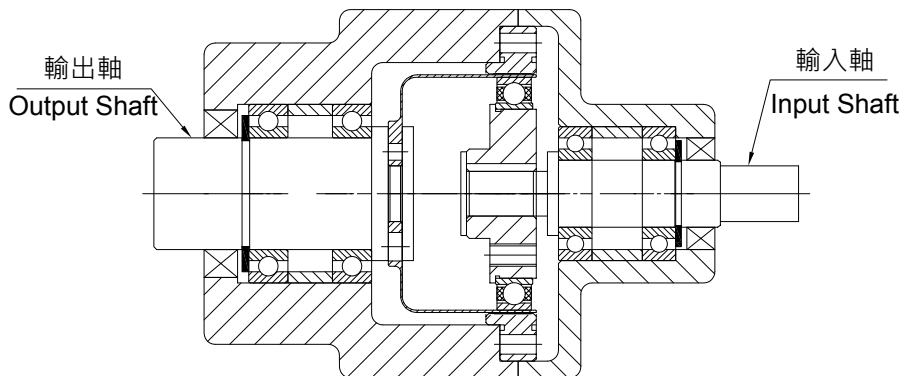

安裝方法 (DSF) Attachment Flang Requirement

安裝與杯型柔性齒輪相連接的法蘭時，為了防止造成杯型柔性齒輪破損，請保證下表所示尺寸。

For the attachment flange that comes in contact with cup-type flex gear, please build the corner radius according to the table below, in order to prevent damage.

unit: mm

型號 Model	14	17	20	25	32	40
R	0.5	0.5	0.5	0.5	0.5	0.5
D	23	26	31	38	50	65

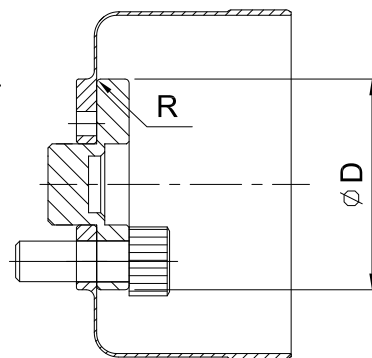

電機安裝用法蘭尺寸 (DSF) Size Requirement of the Flange for Motor Attachment

將電機安裝至組合型元件產品時，需要安裝專用法蘭。
電機安裝專用法蘭尺寸請按照下表所示要求執行。

An attachment flange is required in order to attach a unit type to the motor. The table below shows the dimension requirement for the flange.

unit: mm

型號 Model	14	17	20	25	32	40
B	56	63	78	86	113	127
T	38H7	48H7	56H7	68H7	90H7	110H7
t	3	3	3.5	4	4	5
a	0.03	0.04	0.04	0.04	0.04	0.04
b	0.03	0.04	0.04	0.04	0.04	0.04

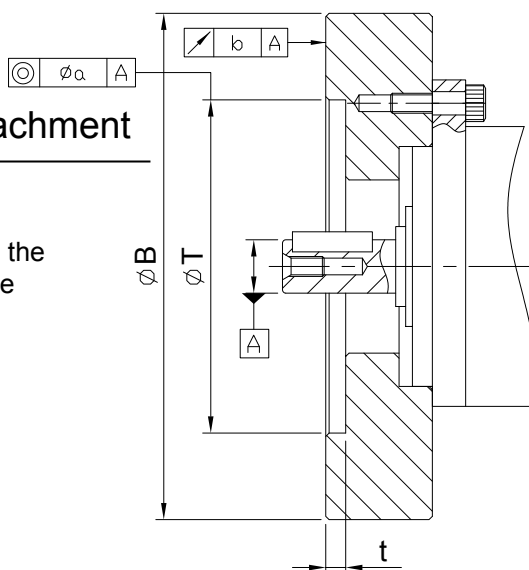

壽命 Service Life

波產生器的壽命 Service Life of the Wave Generator

減速機的使用壽命，由波產生器軸承的壽命決定。和一般滾珠軸承相同，由轉速與負載轉矩計算求出。
 The service life of reducer is determined by the service of the wave generator bearing, and you can calculate this by the rotational speed and the load torque just as with a general ball bearing.

壽命時間 Service Life

機型 Type	DSF、DHF
L_{10} (10% 受損機率 Damage Probability)	7,000 horus
L_{50} (平均壽命 Average Service Life)	35,000 horus

※ 額定表記載之額定轉速、額定轉矩下的運轉壽命。

Service is based on the rated rotational speed and rated torque from the ratings.

依據實際運轉條件的壽命時間 (L_h) 公式

Calculation formula for service Life (L_h) by actual operation condition

$$L_h = L_n \cdot \left(\frac{Tr}{Tav}\right)^3 \left(\frac{Nr}{Nav}\right)$$

L_n : L_{10} 或 L_{50} 時的壽命時間 Service Life of L_{10} or L_{50}

Tr : 額定轉矩 Rated Torque

Nr : 額定轉速 Rated Rotational Speed

Tav : 輸出端的平均負載轉矩 Average Load Torque on the Output Side

Nav : 平均輸入轉速 Average Input Rotational Speed

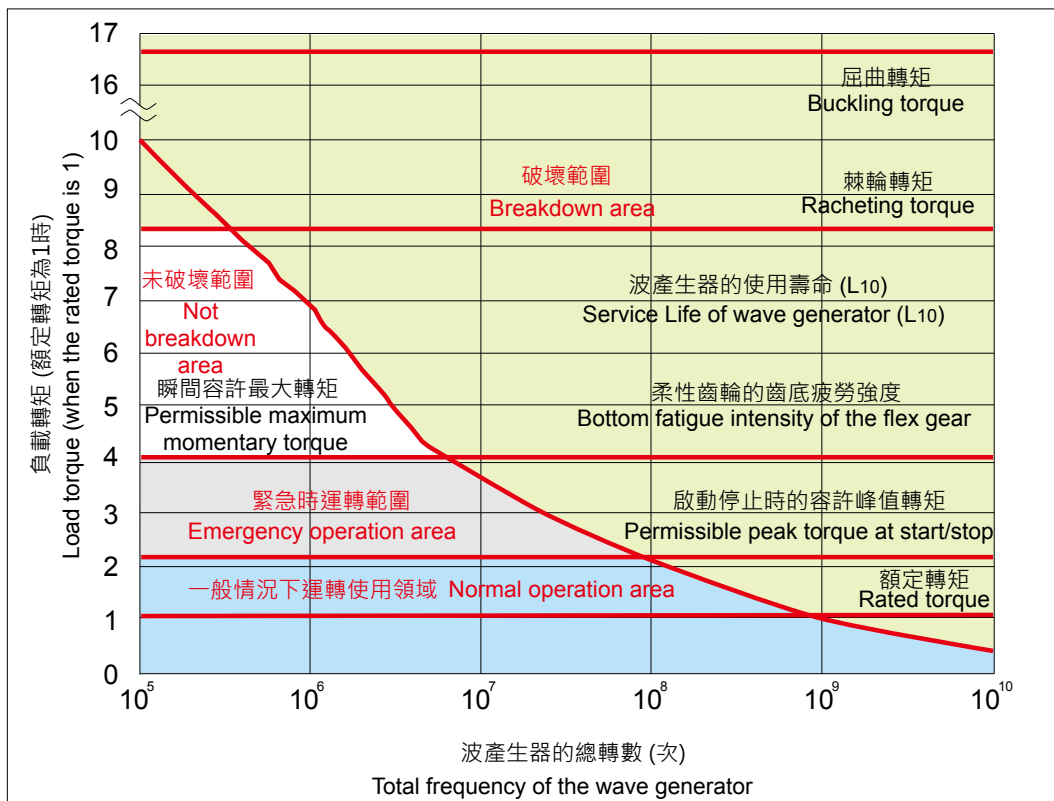

請維持在「一般時運轉使用區域」中使用。若超出「一般時運轉使用區域」使用範圍，將加速減速機的損壞。
 上述圖表未考慮齒面磨耗等潤滑壽命，請以上述圖表作為參考值。

Use it within the range of "Normal operation area". Using it beyond "Emergency operation area" may result in damaging reducer earlier than usual.

Lubricant life such as for abrasion on the tooth surface is not taken into consideration in the graph described above. Use the graph above as reference values.

強度 Intensity

柔性齒輪的強度 Intensity of Flex Gear

柔性齒輪會反覆發生彈性變形，所以減速機的傳動轉矩以柔性齒輪的齒根疲勞強度為基準。額定轉矩、起動與停止時的容許峰值轉矩等數值，為柔性齒輪的齒根疲勞極限之內的數值。若施加超過起動或停止峰值轉矩的衝擊轉矩，恐將產生疲勞破壞。為了避免產生疲勞破壞，設有衝擊轉矩的施加次數限制。但衝擊轉矩的最大值不得超過瞬間容許最大轉矩。

As flexs gear repeats elastic deformation, the transmission torque of reducer is calculated based on the fatigue strength of the bottom of the flex gear.

Values of the rated torque and permissible peak torque for start and stop are those within the fatigue limit of the bottom of the flexs gear.

If impact torque that exceeds the peak torque for start and stop is applied, it could generate fatigue fracture.

Therefore, the number of applications of impact torque is limited to prevent possible fatigue fracture.

However, the maximum value of the impact torque cannot exceed the permissible maximum momentary torque.

在波產生器承受衝擊轉矩時，柔性齒輪的彈性變形次數限制：

Restriction on the bending frequency of the flexs gear by the rotation of the wave generator while the impact torque is applied:

1.0×10^4 (次 frequency)

基於此一彈性變形次數限制，可求出衝擊轉矩施加的容許次數。

You can calculate the permissible frequency of impact torques from this restriction on the bending frequency.

計算公式 Calculation Formula

$$N = \frac{1.0 \times 10^4}{2 \times \frac{n}{60} \times t}$$

容許次數	Permissible Frequency	: N 次
衝擊轉矩的施加時間	Time that Impact Torque is Applied	: t sec
當時的波產生器轉速	Rotational Speed of the Wave Generator	: n r/min

波產生器旋轉 1 圈，將使柔性齒輪產生 2 次彈性變形。

The flexs gear bends two times by one cycle of the wave generator.

屈曲轉矩 Buckling Torque

波產生器為固定狀態下，對柔性齒輪（輸出）施加過度轉矩時，將引起柔性齒輪的塑性變形，並將導致柔性齒輪中部發生屈曲，進而破損。此時的轉矩，稱為屈曲轉矩。

When excess torque is applied to the flexs gear (output) with the wave generator fixed, the flexs gear causes elastic deformation, buckles on the body before long and will be destroyed. The torque at the time is called buckling torque.

棘輪轉矩 Ratcheting Torque

運轉中若施加過度的衝擊轉矩，可能出現柔性齒輪未破損，但剛性齒輪與柔性齒輪的嚙合瞬間脫開的情況。此一現象稱為棘輪效應，此時的轉矩稱為棘輪轉矩。

When excess impact torque is applied during operation, the engagement of the teeth between the internal gear and the flexs gear may be put momentarily out of alignment instead of damaging the flexs gear. This phenomenon is called ratcheting, and the torque is called "ratcheting torque".

剛性 Stiffness

固定輸入側，將力矩施加至輸出側時的彈簧常數與扭曲角度。

In this context, stiffness is the output shaft twisting angle and the spring coefficient, while torque load is applied to the output shaft with input side fixed.

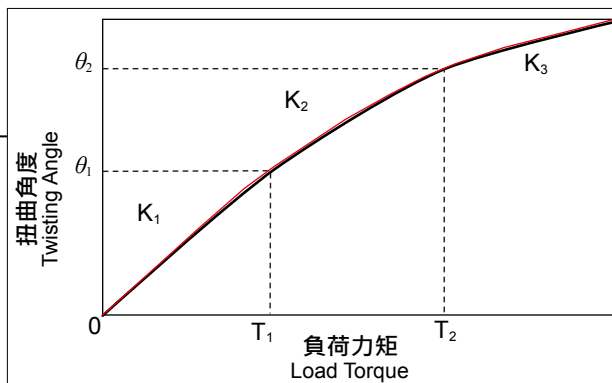

K_1 力矩 $0 \sim T_1$ 的彈簧常數

Spring coefficient at $0 \sim T_1$ torque

K_2 力矩 $T_1 \sim T_2$ 的彈簧常數

Spring coefficient at $T_1 \sim T_2$ torque

K_3 力矩 $T_2 \sim$ 的彈簧常數

Spring coefficient at $T_2 \sim$ torque

減速比 Ratio	代號	單位 Unit	14	17	20	25	32	40	45
-	T_1	Nm	2	4	8	16	30	62	76
-	T_2	Nm	6.8	12	24	50	110	210	280
50	K_1	$\times 10^4 \text{Nm/rad}$	0.28	0.70	1.20	2.80	5.60	11.00	15.00
	K_2	$\times 10^4 \text{Nm/rad}$	0.45	0.86	1.80	3.40	7.20	14.00	20.00
	K_3	$\times 10^4 \text{Nm/rad}$	0.60	1.70	2.60	4.20	8.50	18.00	24.00
	θ_1	arcmin	2.45	1.96	2.29	1.72	1.84	1.93	1.74
	θ_2	arcmin	5.19	4.79	4.58	5.05	5.25	4.51	4.80
80 100 120	K_1	$\times 10^4 \text{Nm/rad}$	0.46	0.92	1.50	3.40	7.00	12.00	17.00
	K_2	$\times 10^4 \text{Nm/rad}$	0.65	1.20	1.80	3.80	8.20	18.00	23.00
	K_3	$\times 10^4 \text{Nm/rad}$	0.70	1.80	2.60	4.60	9.70	22.00	29.00
	θ_1	arcmin	1.50	1.50	1.80	1.62	1.47	1.78	1.54
	θ_2	arcmin	3.59	3.43	4.58	4.52	4.60	4.00	4.18

※ 表中數值為平均值。 Average value shown in the table.

入力軸容許負荷 Maximum Load at Input Shaft

軸承規格 Bearing Specification

unit: N

系列 Series	型號 Model	軸承 A Bearing A		軸承 B Bearing B		a	b
		基本動態額負荷 Basic Dynamic Load Rating	基本靜態額負荷 Basic Static Load Rating	基本動態額負荷 Basic Dynamic Load Rating	基本靜態額負荷 Basic Static Load Rating		
		Co	Cor	Co	Cor		
		N	N	N	N		
						mm	mm
DHF-O	14	5,000	2,450	5,000	2,400	16	27.5
	17	5,400	2,950	5,400	2,950	16.0	31.0
	20	5,650	3,400	5,650	3,400	14.5	27.5
	25	6,150	4,200	6,150	4,200	15.5	31
	32	17,700	10,900	8,200	6,100	20.0	36.0
	40	25,200	17,300	14,300	10,600	24.5	43.5
	45	21,700	16,100	14,900	11,500	24.5	46.5
DHF-S	14	5,700	1,950	2,800	910	23	23
	17	6,400	2,400	2,800	910	25.0	25.5
	20	7,000	2,850	2,800	910	30.5	27.5
	25	7,500	3,250	5,400	2,250	36.0	30.5
	32	11,700	5,050	7,000	2,850	39.0	37.0
	40	17,500	7,850	11,700	5,050	46.5	45.0
	45	17,500	7,850	12,600	5,850	46.5	50.5

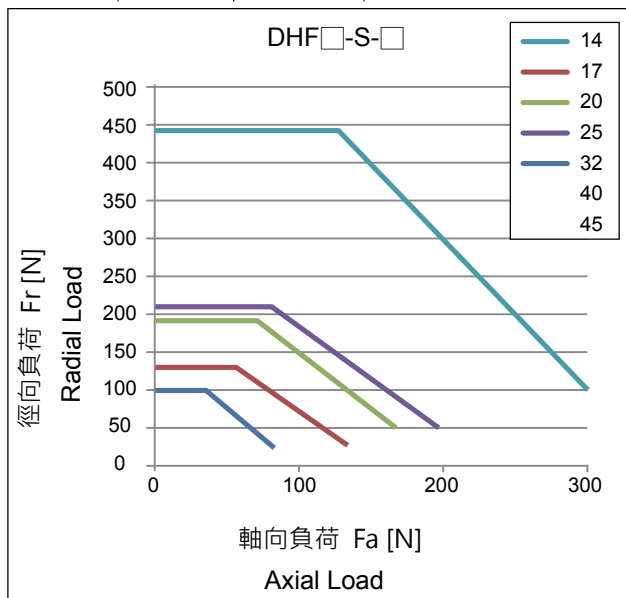
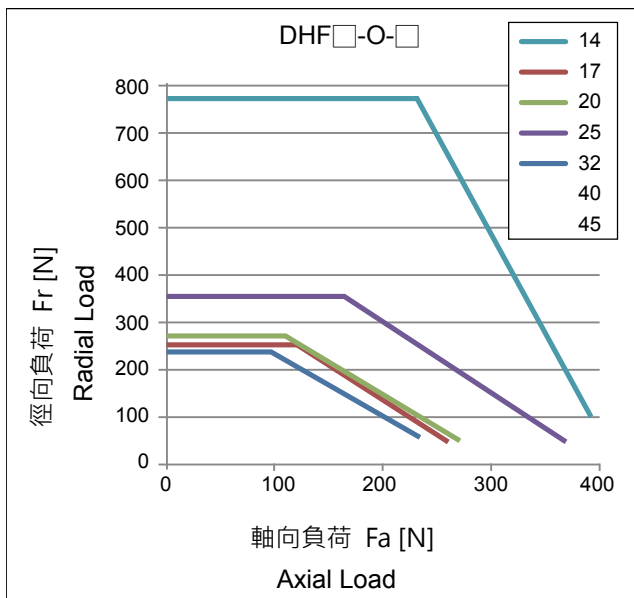
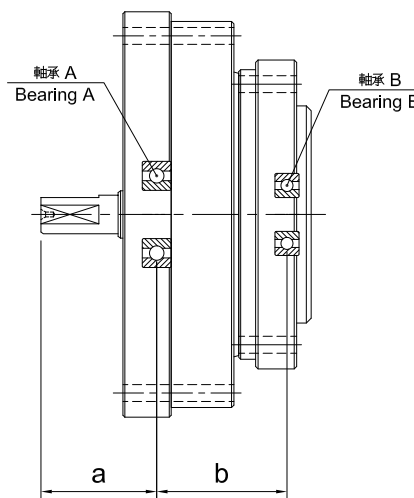
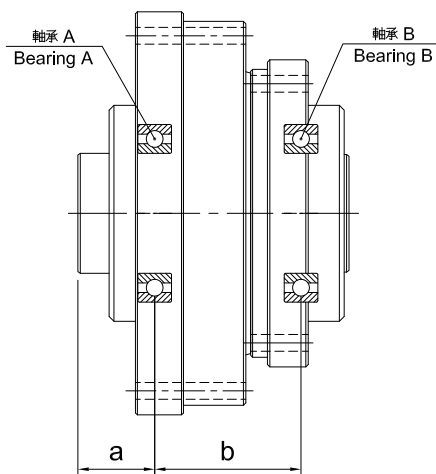

主軸承 Main Bearing

主軸承規格 (交叉圓柱滾子軸承)

Main Bearing Specification (Crossed Roller Bearing)

機型 Type	型號 Model	滾軸節圓直徑 Pitch Circle Diameter of the Bearing Rollers	偏移量 Offset	基本動態額定負荷 Basic Dynamic Load Rating	基本靜態額定負荷 Basic Static Load Rating	容許力矩荷重 Allowable Moment	力矩剛性 Moment Rigidity
		Dm	L	Cr	Cor	Mc	Km
		mm	mm	N	N	kgfm	kgfm/arcmin
DSF	14	32.8	9.5	4,800	7,200	4.2	1.3
	17	38.5	9.5	5,500	8,250	6.5	2.3
	20	46.2	9.5	7,050	10,580	9.3	3.8
	25	57.6	11.5	9,900	14,800	16	7.2
	32	76.8	12.5	12,900	19,300	32	16
	40	92.0	14.5	16,800	25,200	46	27
DHF-AC DHF-AK	14	53.8	10.3	6,000	8,800	7.6	2.5
	17	61.5	11.9	10,700	16,800	12.6	4.6
	20	70.4	12.0	15,000	22,700	19.1	7.5
	25	84.5	14.1	22,400	37,000	26.3	11.6
	32	108.0	15.9	39,400	65,100	59.1	29.6
	40	135.0	19.0	44,600	74,000	86.6	53.2
DHF-O DHF-S	45	154.0	20.5	65,400	98,000	115	76.3
	14	53.8	21.8	6,000	8,800	7.6	2.5
	17	61.5	23.9	10,700	16,800	12.6	4.6
	20	70.4	25.5	15,000	22,700	19.1	7.5
	25	84.5	29.6	22,400	37,000	26.3	11.6
	32	108.0	36.4	39,400	65,100	59.1	29.6
	40	135.0	44.5	44,600	74,000	86.6	53.2
	45	154.0	47.5	65,400	98,000	115	76.3

主軸承壽命計算 Part Life Span for the Main Bearing

運轉類型 Operation Cycle Example

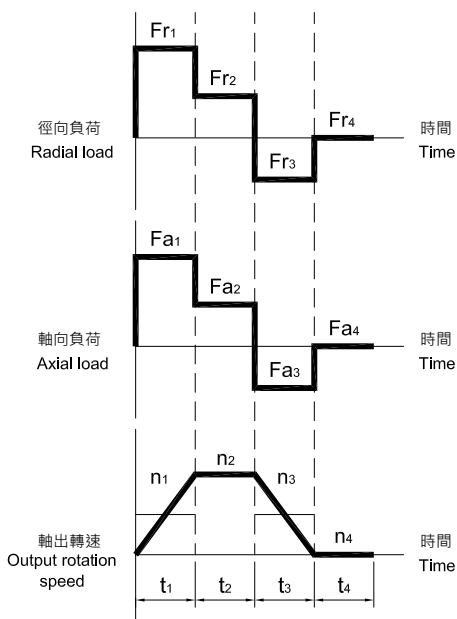

外部負荷 External Load

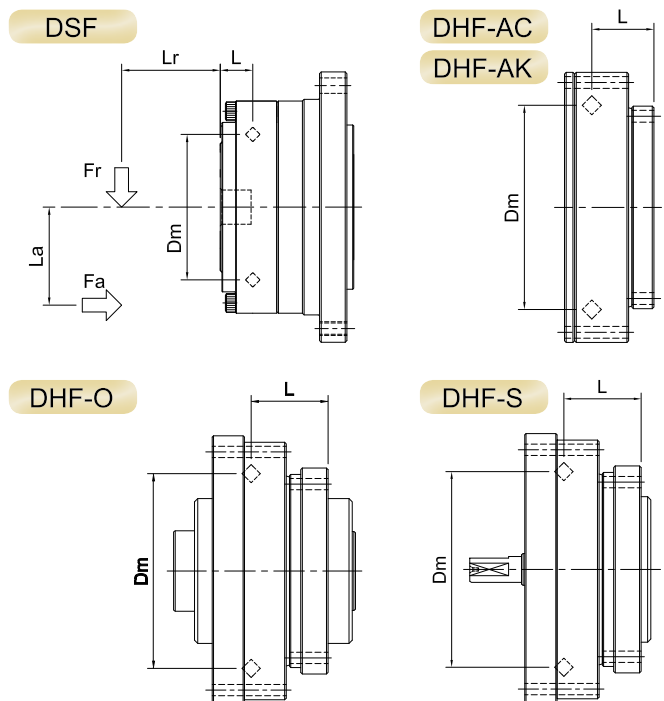

特性數據 Characteristics Data

角度傳導精度

Transmission Angular Accuracy

unit: arcmin

在無負荷條件下使入力軸旋轉時，理論上輸出旋轉角度與實際輸出旋轉角度的差值。

It is the difference between the measured output rotation angle and the theoretical angle, while input shaft is rotated with no load.

機型 Type	減速比 Ratio	14	17	20	25	32	40	45
DSF	50	2.0	2.0	1.5	1.0	1.0	1.0	-
	80	1.5	1.5	1.0	1.0	1.0	1.0	-
	100	1.5	1.5	1.0	1.0	1.0	1.0	-
	120	-	1.5	1.0	1.0	1.0	1.0	-
DHF	50	2.0	2.0	1.5	1.0	1.0	1.0	1.0
	80	1.5	1.5	1.0	1.0	1.0	1.0	1.0
	100	1.5	1.5	1.0	1.0	1.0	1.0	1.0
	120	-	1.5	1.0	1.0	1.0	1.0	1.0

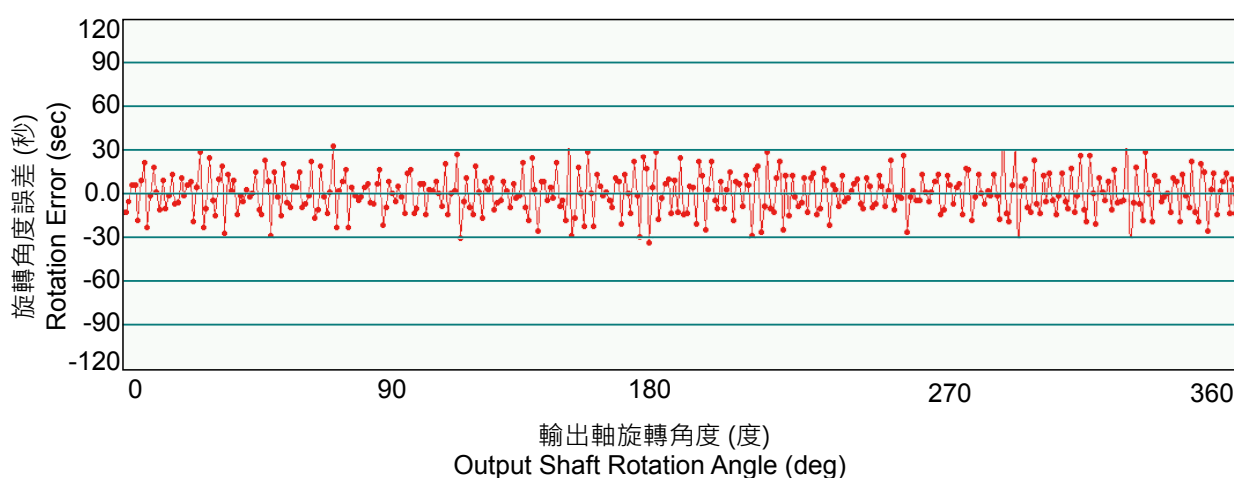

滯後損失 Hysteresis Loss

unit: arcmin

輸入側固定後，將力矩施加至輸出側且 0 力矩時的扭曲角度差。

When torque load is applied at the output shaft in alternate direction repeatedly with input shaft fixed, there is residual twisting angle when torque is back to zero.

In this context, hysteresis loss is the difference in the forward and backward twisting angle.

機型 Type	減速比 Ratio	14	17	20	25	32	40	45
DSF	50	2.0	2.0	2.0	2.0	2.0	2.0	-
	80	1.5	1.5	1.0	1.0	1.0	1.0	-
	100	1.5	1.5	1.0	1.0	1.0	1.0	-
	120	-	1.5	1.0	1.0	1.0	1.0	-
DHF	50	2.0	2.0	2.0	2.0	2.0	2.0	2.0
	80	1.5	1.5	1.0	1.0	1.0	1.0	1.0
	100	1.5	1.5	1.0	1.0	1.0	1.0	1.0
	120	-	1.5	1.0	1.0	1.0	1.0	1.0

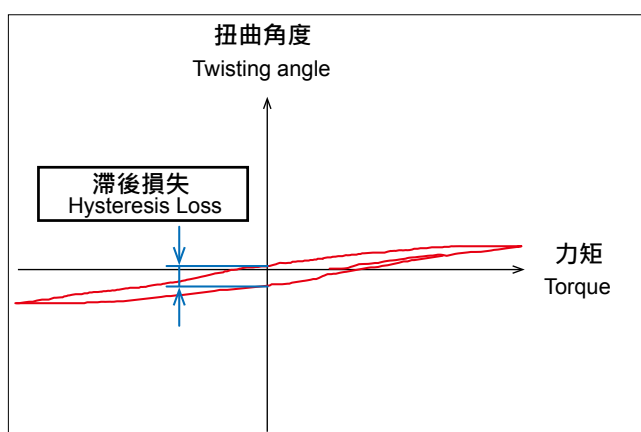

啟動轉矩 Starting Torque

由輸入側使其旋轉時，輸入側開始旋轉的力矩。（平均值，無負荷，環境溫度：25°C）
Input torque needed for input side to start rotating (average value, no load, ambient temperature : 25°C)

增速啟動轉矩 Output Starting Torque

由輸出側使其旋轉時，輸入側開始旋轉的力矩。（平均值，無負荷，環境溫度：25°C）
Output torque needed for input side to start rotating (average value, no load, ambient temperature : 25°C)

無負載運轉力矩 No-load Running Torque

在無負荷條件下轉速 2,000 r/min，使其旋轉所需必要的輸入側力矩。（平均值，無負荷，環境溫度：25°C）
Input torque needed to keep it running with no load speed 2,000 r/min (average value, no load, ambient temperature : 25°C)

額定輸出扭矩 Nominal Output Torque

減速機輸入轉速 2,000 r/min 時，可以長時間加載的扭矩。
The indicates permissible continuous load torque when the input speed is 2,000 r/min.

最大輸出扭矩 Max. Output Torque

啟動、停止時的最大容許值
The maximum torque when starting and stopping.

急停扭矩 Emergency Stop Torque

發生衝擊時的最大容許值
The maximum torque when it receives shock loading.

額定輸入轉速 Nominal Input Speed

運轉時，輸入轉速的容許值
The indicates permissible continuous running input speed.

噪音值 Noise Level

2,000 r/min 距離 1m 無負載量測
Noise level is measured in 2,000 r/min, without loading and in distance from the reducer.

效率 Efficiency

減速機效率會因以下條件有所差異

The efficiency varies depending on the following conditions.

- 減速比 Reducer Ratio
- 輸入轉速 Input Speed
- 負載轉矩 Load Torque
- 溫度 Temperature
- 潤滑條件 Lubrication Condition

樣本上的數值是輸入轉速 2,000 rpm 額定扭矩負載所測得平均值。

The efficiency in our catalog is average value tested at rated torque loading in input speed 2,000 r/min.

DSF14-A□-50

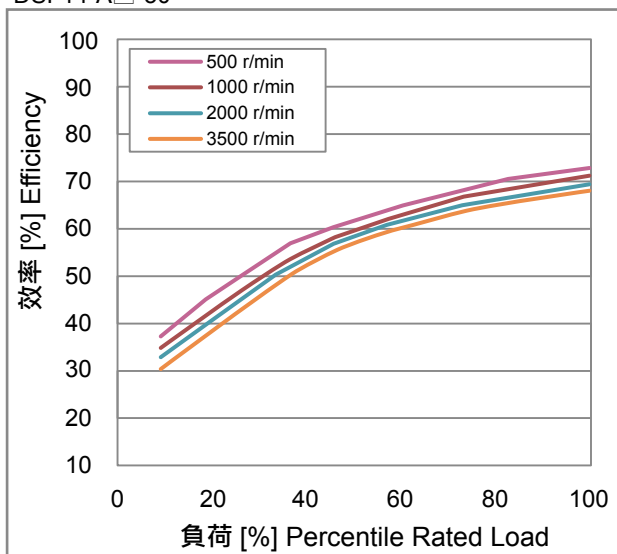

DSF14-A□-80

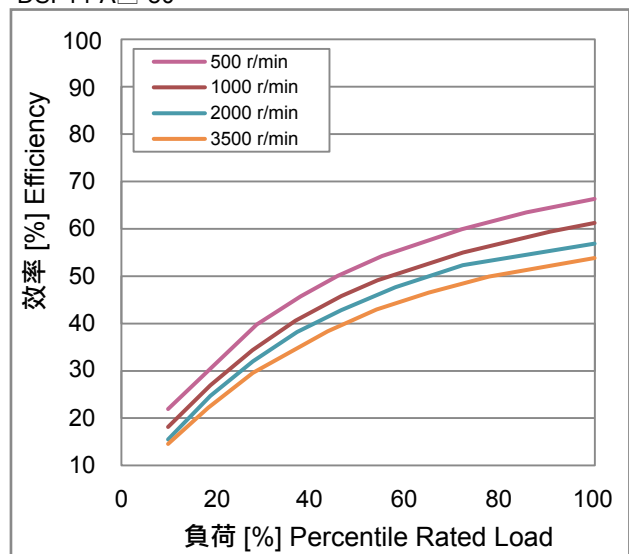

DSF14-A□-100

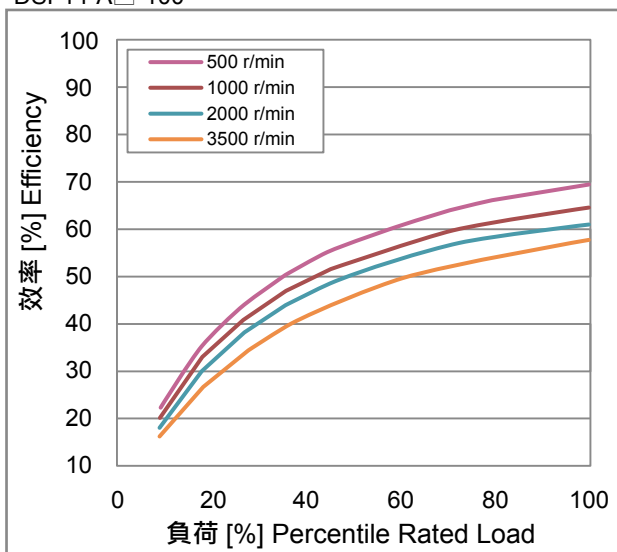

DSF14-A□-120

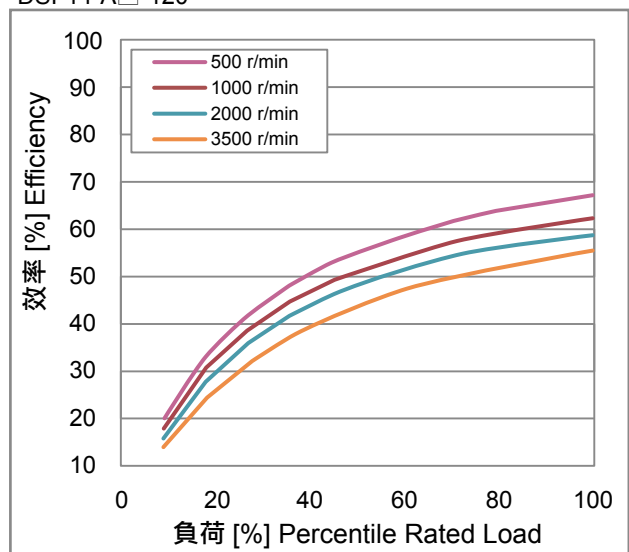



DSF

諧波減速機

機種型號表示 Indication of Model Numbers

DSF		14	P		C	100	MOTOR
減速機機型 Type	型號 Model	樣式 Style	輸入樣式 Input Style	速比 Ratio	馬達型號 Motor Type		
DSF	14 17 20 25 32 40	P: 組件式 Component Type A: 組合式 Unit Type MC: 法蘭式 Motor Flange Type S: 輸入軸式 Input Shaft Type	C: 輸入迫緊 Input Collet K: 輸入鍵槽 Input Keyway 樣式 P、A 可以選擇 輸入樣式 Input style is optional for style P, A.	1/50 1/80 1/100 1/120			

DSF □ -PC- □

PC

- 組件式 - 輸入迫緊
Component Type - Input Collet



DSF □ -AC- □

AC

- 組合式 - 輸入迫緊
Unit Type - Input Collet



DSF □ -MC- □

MC

- 法蘭式 Motor Flange Type



DSF □ -PK- □

PK

- 組件式 - 輸入鍵槽
Component Type - Input Keyway



DSF □ -AK- □

AK

- 組合式 - 輸入鍵槽
Unit Type - Input Keyway



DSF □ -S- □

S

- 輸入軸式 Input Shaft Type



DSF 產品特性 Characteristic of DSF

規格 Model No.	單位 Unit	減速比 Ratio	14	17	20	25	32	40
額定輸出扭矩 Nominal Output Torque	Nm	50	5.4	17	27	42	80	140
		80	7.8	23	36	66	122	210
		100	7.8	25	42	70	140	270
		120	-	28	45	72	142	300
最大輸出扭矩 Max. Output Torque	Nm	50~120	2 倍額定輸出扭矩 2 Times of Rated Output Torque					
急停扭矩 Emergency Stop Torque	Nm	50~120	3 倍額定輸出扭矩 3 Times of Rated Output Torque					
啟動轉矩 Starting Torque	cNm	50	4	6	8	15	32	55
		80	3	4	5	9	20	35
		100	2.5	3.5	4	8	18	32
		120	-	3	4	7	15	28
增速啟動轉矩 Output Starting Torque	Nm	50	1.6	3.2	4.8	10	20	36
		80	1.8	3.3	4.8	11	21	38
		100	1.9	3.4	5	12	22	40
		120	-	3.5	6	12	24	42
無負載運轉力矩 No-load Running Torque	cNm	50	5	10	14	18	31	60
		80	4	9	13	17	30	58
		100	3	8	12	16	29	54
		120	-	7	11	15	28	50
額定輸入轉速 Nominal Input Speed	rpm	50~120	2,000	2,000	2,000	2,000	2,000	2,000
最大輸入轉速 Max. Input Speed	rpm	50~120	6,000	6,000	5,000	5,000	5,000	4,000
慣性力矩 Reducer Inertia	lx10-4kgm2	50~100	0.04	0.08	0.2	0.4	1.7	4.5
效率 Efficiency	%	50	70	73	73	73	75	75
		80	68	70	72	72	74	74
		100	64	66	70	70	72	72
		120	-	64	68	68	70	70
使用溫度 Operating Temperature	°C	50~120	環境 Environment -10°C ~ +70°C / 最大工作溫度 Max. Working Temperature 90°C					
潤滑 Lubrication		50~120	全合成潤滑油脂 Synthetic Grease No.2					
噪音值 Noise Level	dB	50~120	52	54	56	58	60	62



MODEL : DSF-PC

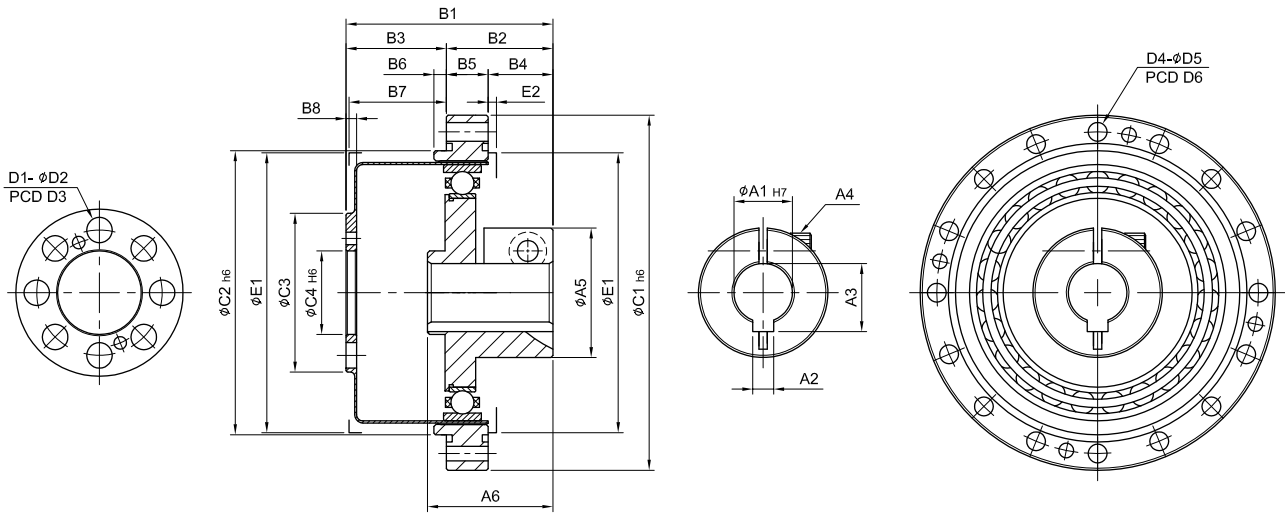
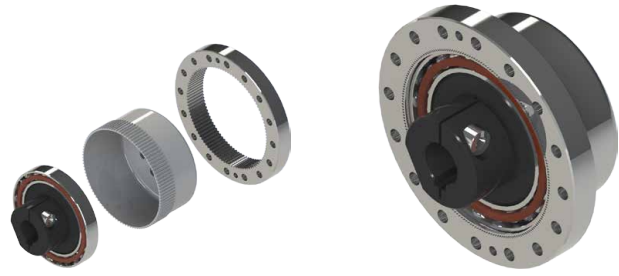

Code \ Model	14	17	20	25	32	40
A1	8	8	8、11、14	14	14、19	19
A2	3	3	3、4、5	5	5、6	6
A3	9.4	9.4	9.4、12.7、16.3	16.3	16.3、21.8	21.8
A4	M4xP0.7	M4xP0.7	M4xP0.7、M5xP0.8	M5xP0.8	M5xP0.8	M5xP0.8
A5	23.5	23.5	23.5、26.5、31	31	34、38	38
A6	22	23	25.5、27.5	30	32.5	36.5
B1	36	39	42.5、44.5	49.5	58	67.5
B2	18.5	19.5	21、23	25.5	30	33.5
B3	17.5	19.5	21.5	24	28	34
B4	12.5	12.5	13.5、15.5	15.5	16	16.5
B5	6	7	7.5	10	14	17
B6	2	2	3	3	3	4
B7	16.5	18.5	20.5	23	27	33
B8	2	2.5	2.5	2.5	2.5	4
C1	50	60	70	85	110	135
C2	38	47	54	68	88	108
C3	23	26	31	38	50	64
C4	11	10	14	20	26	32
D1	6	6	8	8	8	8
D2	4.1	5.1	5.1	6.1	8.1	10.1
D3	17	19	24	30	40	50
D4	8	16	16	16	16	16
D5	3.5	3.5	3.5	4.5	5.5	6.5
D6	44	54	62	77	100	122
E1	38	46	54	67	86	105
E2	1.5	1.5	2	2	2	3
O-Ring	d35 x 1.0t	d44 x 1.2t	d51.82 x 1.5t	d63.22 x 1.78t	d84.5 x 2.0t	d107.62 x 2.62t
Weight (g)	132	195	300	495	1,018	3,383

MODEL : DSF-PK

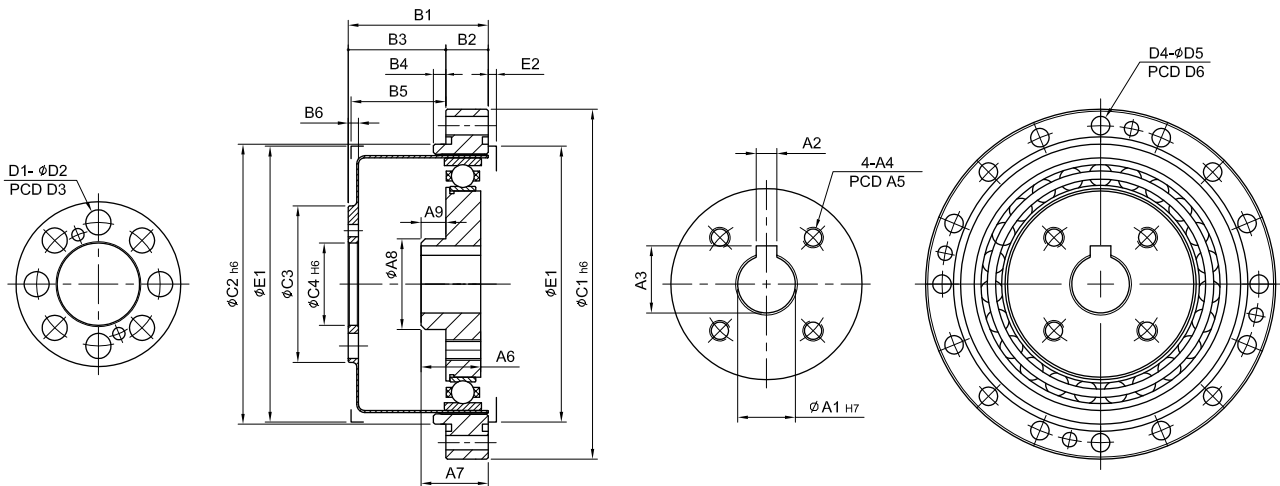

Code \ Model	14	17	20	25	32	40
A1	6、8	8	8、14	14	14、19	19、24
A2	2、3	3	3、5	5	5、6	6、8
A3	7、9.4	9.4	9.4、16.3	16.3	16.3、21.8	21.8、27.3
A4	2-M4xP0.7	2-M4xP0.7	M4xP0.7	M5xP0.8	M5xP0.8	M5xP0.8
A5	18	22	25	32	36	50
A6	10	12.5	13.5	14.5	16	20
A7	10.5	13	14	16.3	17.45	22
A8	14	16	20	22	30	32、33
A9	2.3	4.2	4.3	6	5	7
B1	23.5	26.5	29	34	42	51
B2	6	7	7.5	10	14	17
B3	17.5	19.5	21.5	24	28	34
B4	2	2	3	3	3	4
B5	16.5	18.5	20.5	23	27	33
B6	2	2.5	2.5	2.5	2.5	4
C1	50	60	70	85	110	135
C2	38	47	54	68	88	108
C3	23	26	31	38	50	64
C4	11	10	14	20	26	32
D1	6	6	8	8	8	8
D2	4.1	5.1	5.1	6.1	8.1	10.1
D3	17	19	24	30	40	50
D4	8	16	16	16	16	16
D5	3.5	3.5	3.5	4.5	5.5	6.5
D6	44	54	62	77	100	122
E1	38	46	54	67	86	105
E2	1.5	1.5	2	2	2	3
O-Ring	d35x1.0t	d44x1.2t	d51.82x1.5t	d63.22x1.78t	d84.5x2.0t	d107.62x2.62t
Weight (g)	100	167	246	446	938	3,297

MODEL : DSF-AC

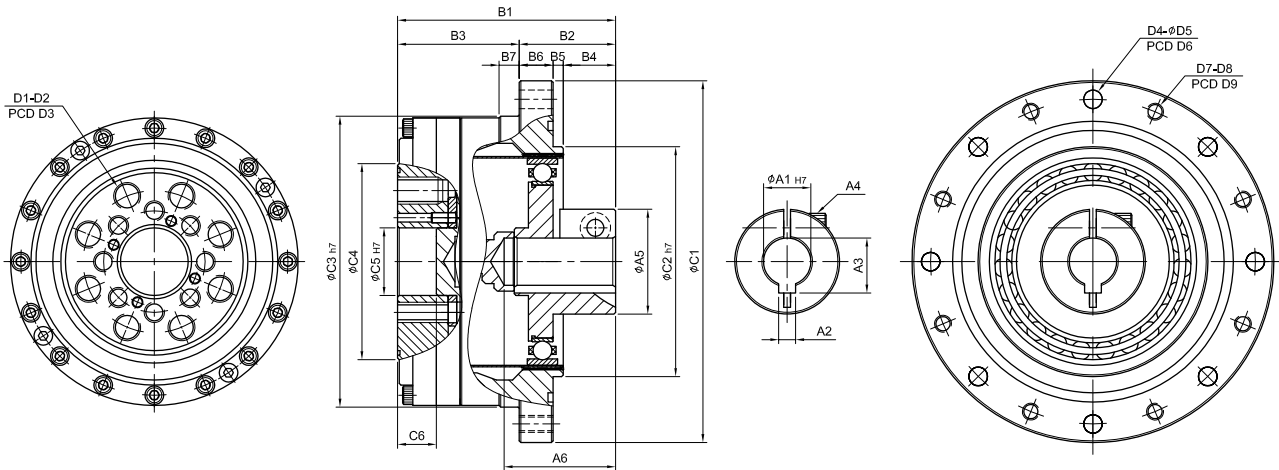

Code \ Model	14	17	20	25	32	40
A1	8	8	8、11、14	14	14、19	19
A2	3	3	3、4、5	5	5、6	6
A3	9.4	9.4	9.4、12.7、16.3	16.3	16.3、21.8	21.8
A4	M4xP0.7	M4xP0.7	M4xP0.7、M5xP0.8	M5xP0.8	M5xP0.8	M5xP0.8
A5	23.5	23.5	23.5、26.5、31	31	34、38	38
A6	23.5	24.5	27、29	33	38.5	46
B1	48.5	51.5	54.5、56.5	64.5	76	87
B2	21.5	22.5	26.5、28.5	28.5	31	36.5
B3	27	29	28	36	45	50.5
B4	12.5	12.5	13.5、15.5	15.5	16	16.5
B5	2	2	3	3	3	4
B6	7	8	10	10	12	16
B7	4	5	6	6	5	5
C1	73	79	93	107	138	160
C2	38	48	56	67	90	110
C3	56	63	72	86	113	127
C4	31	38	45	58	78	90
C5	11	10	14	20	26	32
C6	9	9	8.5	11.5	14.5	5
D1	6	6	8	8	8	8
D2	M4xP0.7	M5xP0.8	M6xP1.0	M8xP1.25	M10xP1.5	M10xP1.5
D3	23	27	32	42	55	68
D4	8	8	8	10	12	10
	6	6	6	8	8	8
D5	4.5	4.5	5.5	5.5	6.5	9
D6	65	71	82	96	125	144
D7	6	6	6	8	8	8
D8	M4xP0.7	M4xP0.7	M5xP0.8	M5xP0.8	M6xP1.0	M8xP1.25
D9	65	71	82	96	125	144
O-Ring	d49.5x2t	d55.5x2t	d66.5x2t	d79.5x2.0t	d104.5x2t	d124.5x2t
Output O-Ring	d29x0.6t	d35x0.6t	d43x1.5t	d55x1.5t	d72x1.5t	d85x1.5t
Weight (g)	555	733	1,039	1,629	3,463	5,174

MODEL : DSF-AK

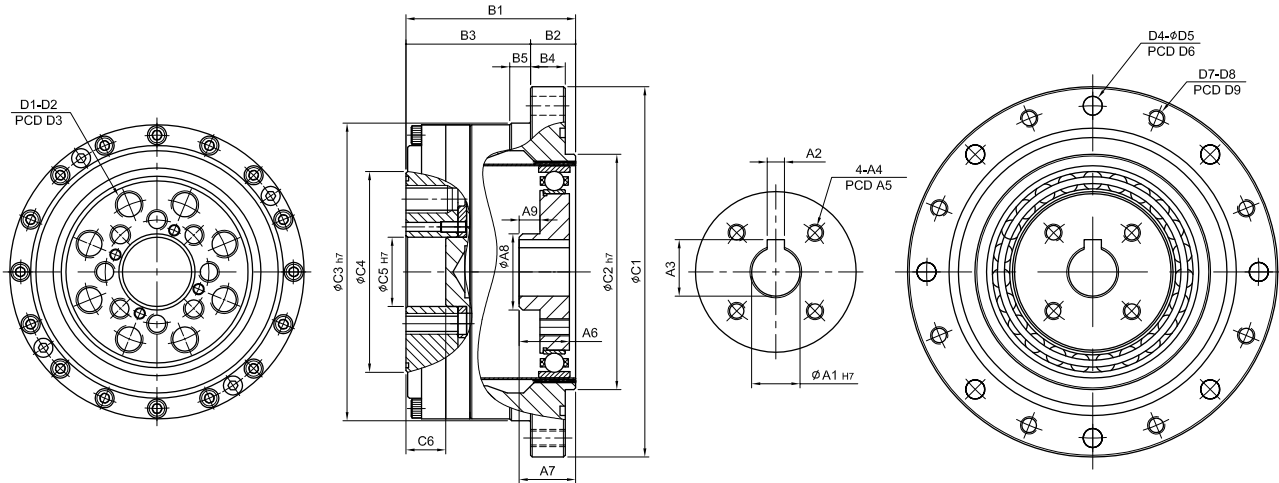

Code \ Model	14	17	20	25	32	40
A1	6、8	8	8、14	14	14、19	19、24
A2	2、3	3	3、5	5	5、6	6、8
A3	7、9.4	9.4	9.4、16.3	16.3	16.3、21.8	21.8、27.3
A4	2-M4xP0.7	2-M4xP0.7	M4xP0.7	M5xP0.8	M5xP0.8	M5xP0.8
A5	18	22	25	32	36	50
A6	10	12.5	13.5	14.5	16	20
A7	10.5	13	14	16.3	17.45	22
A8	14	16	20	22	30	32、33
A9	2.3	4.2	4.3	6	5	7
B1	36	39	41	49	60	70.5
B2	9	10	13	13	15	20
B3	27	29	28	36	45	50.5
B4	7	8	10	10	12	16
B5	4	5	5	6	5	5
C1	73	79	93	107	138	160
C2	38	48	56	67	90	110
C3	56	63	72	86	113	127
C4	31	38	45	58	78	90
C5	11	10	14	20	26	32
C6	9	9	8.5	11.5	14.5	5
D1	6	6	8	8	8	8
D2	M4xP0.7	M5xP0.8	M6xP1.0	M8xP1.25	M10xP1.5	M10xP1.5
D3	23	27	32	42	55	68
D4	8	8	8	10	12	10
D5	6	6	6	8	8	8
D6	4.5	4.5	5.5	5.5	6.5	9
D7	65	71	82	96	125	144
D8	6	6	6	8	8	8
D9	M4xP0.7	M4xP0.7	M5xP0.8	M5xP0.8	M6xP1.0	M8xP1.25
O-Ring	d49.5x2t	d55.5x2t	d66.5x2t	d79.5x2.0t	d104.5x2t	d124.5x2t
Output O-Ring	d29x0.6t	d35x0.6t	d43x1.5t	d55x1.5t	d72x1.5t	d85x1.5t
Weight (g)	523	705	985	1,581	3,383	5,084

MODEL : DSF-MC

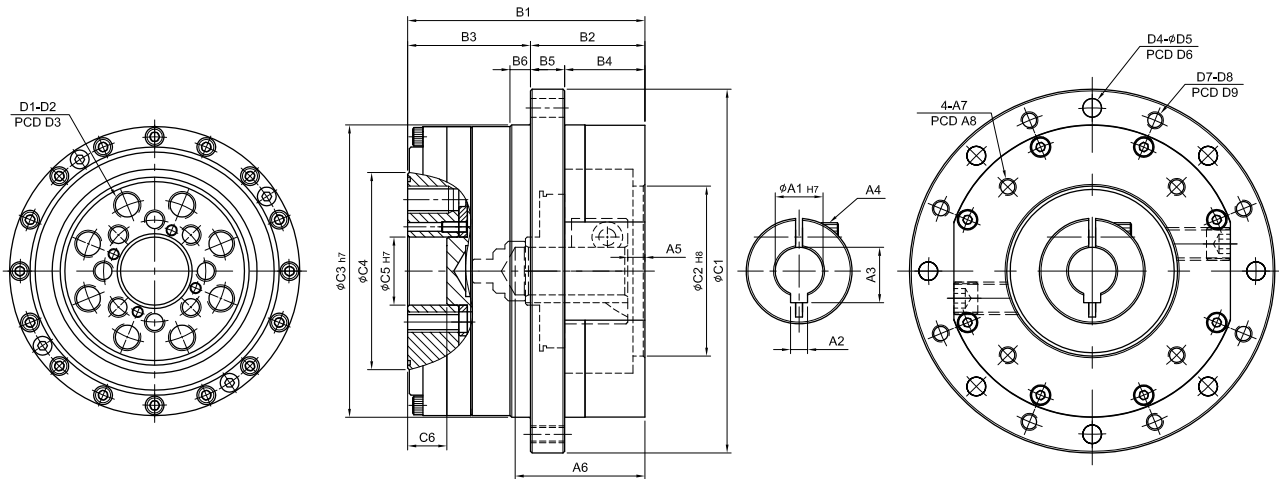

Code \ Model	14	17	20	25	32	40
A1	8	8	8、11、14	14	14、19	19
A2	3	3	3、4、5	5	5、6	6
A3	9.4	9.4	9.4、12.7、16.3	16.3	16.3、21.8	21.8
A4	M4xP0.7	M4xP0.7	M4xP0.7、M5xP0.8	M5xP0.8	M5xP0.8	M5xP0.8
A5	4	4	4、5	5	5	5
A6	27.5	28.5	31、34	38	43.5	51
A7	M4xP0.7	M4xP0.7	M4xP0.7	M5xP0.8	M5xP0.8, M6xP1.0	M6xP1.0
A8	46	46	46、70	70	70,90	90
B1	52.5	55.5	58.5、61.5	69.5	81	92
B2	25.5	26.5	30.5、33.5	33.5	36	41.5
B3	27	29	28	36	45	50.5
B4	18.5	18.5	20.5、23.5	23.5	24	25.5
B5	7	8	10	10	12	16
B6	4	5	6	6	5	5
C1	73	79	93	107	138	160
C2	30	30	30、50	50	50,70	70
C3	56	63	72	86	113	127
C4	31	38	45	58	78	90
C5	11	10	14	20	26	32
C6	9	9	8.5	11.5	14.5	5
D1	6	6	8	8	8	8
D2	M4xP0.7	M5xP0.8	M6xP1.0	M8xP1.25	M10xP1.5	M10xP1.5
D3	23	27	32	42	55	68
D4	8	8	8	10	12	10
	6	6	6	8	8	8
D5	4.5	4.5	5.5	5.5	6.5	9
D6	65	71	82	96	125	144
D7	6	6	6	8	8	8
D8	M4xP0.7	M4xP0.7	M5xP0.8	M5xP0.8	M6xP1.0	M8xP1.25
D9	65	71	82	96	125	144
Output O-Ring	d29x0.6t	d35x0.6t	d43x1.5t	d55x1.5t	d72x1.5t	d85x1.5t
Weight (g)	633	836	1,155	1,831	3,881	5,673

MODEL : DSF-S

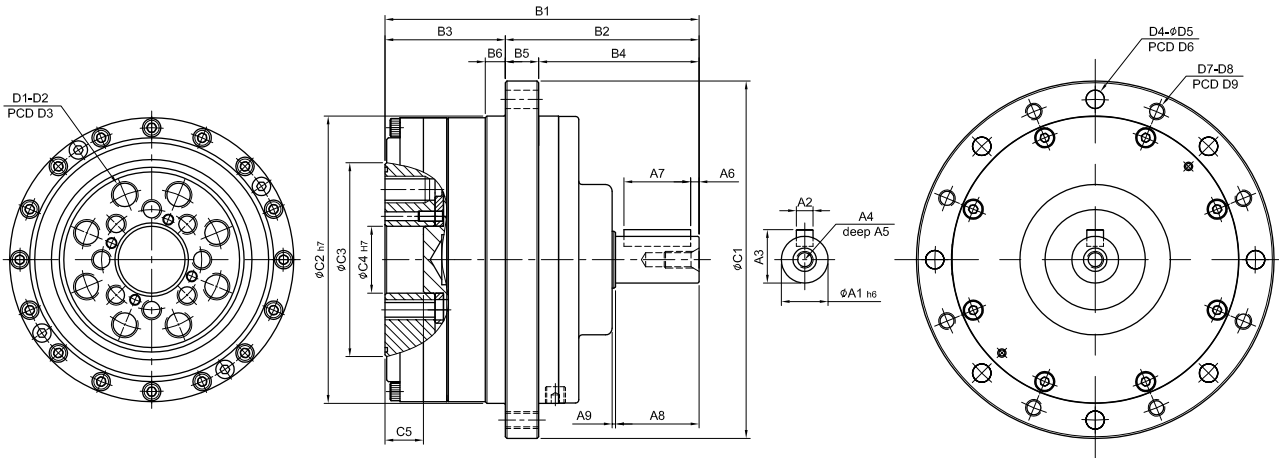

Code \ Model	14	17	20	25	32	40
A1	8	11	11	14	14	19
A2	3	4	4	5	5	6
A3	9.2	12.5	12.5	16	16	21.5
A4	M3xP0.5	M4xP0.7	M4xP0.7	M5xP0.8	M5xP0.8	M6xP1.0
A5	7	8	8	10	10	12
A6	1	1.5	2.5	2.5	2.5	2.5
A7	10	12	15	20	20	25
A8	12	16	20	25	25	30
A9	1	1	1	1	1	1
B1	63.5	70.5	78	94	113.5	129.5
B2	36.5	41.5	50	58	68.5	79
B3	27	29	28	36	45	50.5
B4	29.5	33.5	40	48	56.5	63
B5	7	8	10	10	12	16
B6	4	5	6	6	5	5
C1	73	79	93	107	138	160
C2	56	63	72	86	113	127
C3	31	38	45	58	78	90
C4	11	10	14	20	26	32
C5	9	9	8.5	11.5	14.5	5
D1	6	6	8	8	8	8
D2	M4xP0.7	M5xP0.8	M6xP1.0	M8xP1.25	M10xP1.5	M10xP1.5
D3	23	27	32	42	55	68
D4	8	8	8	10	12	10
	6	6	6	8	8	8
D5	4.5	4.5	5.5	5.5	6.5	9
D6	65	71	82	96	125	144
D7	6	6	6	8	8	8
D8	M4xP0.7	M4xP0.7	M5xP0.8	M5xP0.8	M6xP1.0	M8xP1.25
D9	65	71	82	96	125	144
Output O-Ring	d29x0.6t	d35x0.6t	d43x1.5t	d55x1.5t	d72x1.5t	d85x1.5t
Weight (g)	620	818	1,125	1,842	3,972	5,882



DHF

諧波減速機

機種型號表示 Indication of Model Numbers

DHF	17	A	C	100	L	MOTOR
減速機機型 Type	型號 Model	樣式 Style	入力樣式 Input Style	速比 Ratio	軸向 Shaft Direction	馬達型號 Motor Type
DHF	14 17 20 25 32 40 45	A: 組合式 Unit Type O: 入力中空軸 Hollow Input Shaft S: 入力軸式 Input Shaft Type	C: 入力迫緊 Input Collet K: 入力鍵槽 Input Keyway O: 入力中空軸 Hollow Input Shaft ----- 入力形式 A 可以選擇 樣式 Input style is optional for style A.	1/50 1/80 1/100 1/120 ----- 型號 Model 14# 速比 Ratio 1/50 1/80 1/100	L: 左軸 Left Shaft R: 右軸 Right Shaft ----- 出力形式 O 可 以選擇軸向 Shaft direction is optional for style type O.	

DHF □ -AC- □

AC

- 組合式 - 入力迫緊
Unit Type - Input Collet



DHF □ -O- □

O

- 入力中空軸 Hollow Input Shaft



DHF □ -AK- □

AK

- 組合式 - 入力鍵槽
Unit Type - Input Keyway



DHF □ -S- □

S

- 入力軸式 Input Shaft Type



DHF □ -AO- □

AO

- 組合式 - 入力中空軸
Unit Type - Hollow Input Shaft



DHF 產品特性 Characteristic of DHF

規格 Model No.	單位 Unit	減速比 Ratio	14	17	20	25	32	40	45
額定輸出扭矩 Nominal Output Torque	Nm	50	5.4	17	27	42	80	140	180
		80	7.8	23	36	66	122	210	320
		100	7.8	25	42	70	140	270	350
		120	-	28	45	72	142	300	400
最大輸出扭矩 Max. Output Torque	Nm	50~120	2 倍額定輸出扭矩 2 Times of Rated Output Torque						
急停扭矩 Emergency Stop Torque	Nm	50~120	3 倍額定輸出扭矩 3 Times of Rated Output Torque						
啟動轉矩 Starting Torque	cNm	50	18	30	40	58	86	140	165
		80	23	28	36	56	80	130	150
		100	28	26	34	52	73	120	140
		120	-	24	30	48	68	110	125
增速啟動轉矩 Output Starting Torque	Nm	50	12	16	20	34	50	80	100
		80	18	24	30	50	70	110	130
		100	24	30	40	60	90	130	160
		120	-	36	50	70	100	160	180
無負載運轉力矩 No-load Running Torque	cNm	50	26	31	40	69	104	162	201
		80	30	45	62	95	133	213	266
		100	55	61	81	121	171	268	332
		120	-	72	103	139	202	321	403
額定輸入轉速 Nominal Input Speed	rpm	50~120	2,000	2,000	2,000	2,000	2,000	2,000	2,000
最大輸入轉速 Max. Input Speed	rpm	50~120	6,000	6,000	5,000	5,000	5,000	4,000	4,000
慣性力矩 Reducer Inertia	lx10-4kgm2	50~100	0.15	0.2	0.4	1	3	9	13
效率 Efficiency	%	50	73	73	73	73	75	75	75
		80	70	70	72	72	74	74	74
		100	66	64	68	70	70	72	72
		120	-	62	66	68	70	70	70
使用溫度 Operating Temperature	°C	50~120	環境 Environment -10°C ~ +70°C / 最大工作溫度 Max. Working Temperature 90°C						
潤滑 Lubrication		50~120	全合成潤滑油脂 Synthetic Grease No.2						
噪音值 Noise Level	dB	50~120	54	54	56	58	60	62	64



MODEL : DHF-AC

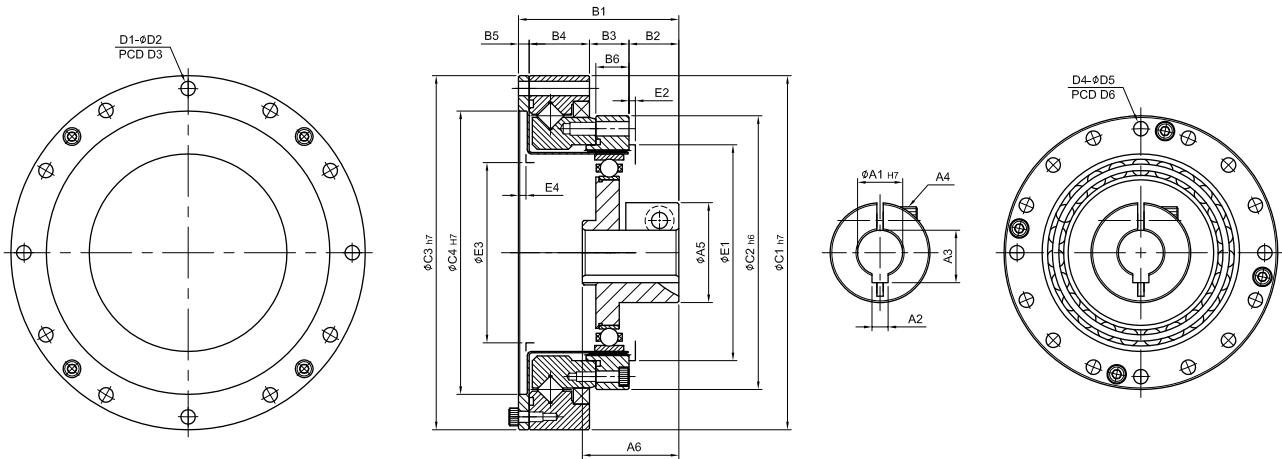

Code \ Model	14	17	20	25	32	40	45
A1	8	8	8、11、14	14	14、19	19	19
A2	3	3	3、4、5	5	5、6	6	6
A3	9.4	9.4	9.4、12.7、16.3	16.3	16.3、21.8	21.8	21.8
A4	M4xP0.7	M4xP0.7	M4xP0.7、M5xP0.8	M5xP0.8	M5xP0.8	M5xP0.8	M5xP0.8
A5	23.5	23.5	23.5、26.5、31	31	34、38	38	38
A6	22	23	25.5、27.5	30	32.5	36.5	38.5
B1	36	39.5	45.5、44.5	49.5	57	64	70
B2	12.5	12.5	13.5、15.5	15.5	16	16	16.5
B3	7	8	8.5	12	15	15	17
B4	14.1	16	17.5	18.7	23.4	29	32
B5	2.4	3	3	3.3	3.6	4	4.5
B6	6	7	7.5	10	14	14	16
C1	70	80	90	110	142	170	190
C2	50	60	70	85	110	135	155
C3	70	80	90	110	142	170	190
C4	48	59.5	70	88	115	138	157.5
D1	8	12	12	12	12	12	18
D2	3.5	3.5	3.5	4.5	5.5	6.5	6.5
D3	64	74	84	102	132	158	180
D4	8	16	16	16	16	16	12
D5	3.3	3.5	3.5	4.5	5.5	6.5	8.5
	M3xP0.5x6L	M3xP0.5x6L	M3xP0.5x6L	M4xP0.7x8L	M5xP0.8x8L	M6xP1.0x10L	M8xP1.25x10L
D6	44	54	62	77	100	122	140
E1	38	46	54	67	86	106	119
E2	1.5	1.5	2	2	2	2	2
E3	30	36	44	56	72	92	105
E4	2	2	2	2	2	2.5	3
Weight (g)	312	595	811	1,328	2,707	4,628	6,732

MODEL : DHF-AK

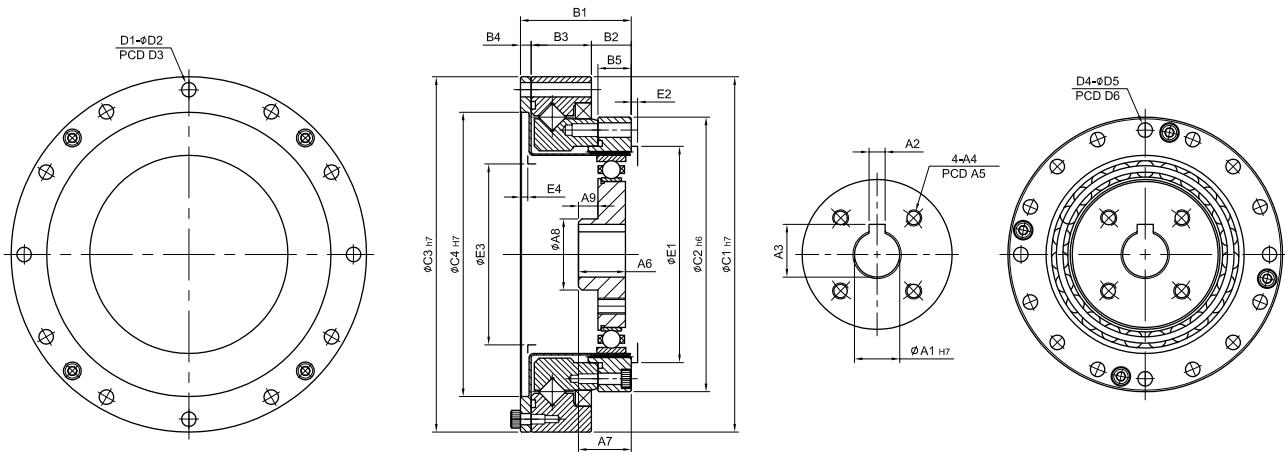

Code \ Model	14	17	20	25	32	40	45
A1	6、8	8	8、14	14	14、19	19、24	19、24
A2	3、3	3	3、5	5	5、6	6、8	6、8
A3	7、9.4	9.4	9.4、16.3	16.3	16.3、21.8	21.8、27.3	21.8、27.3
A4	2-M4xP0.7	2-M4xP0.7	M4xP0.7	M5xP0.8	M5xP0.8	M5xP0.8	M6xP1.0
A5	18	22	25	32	36	50	50
A6	10	12.5	13.5	14.5	16	20	20
A7	10.5	13	14	16.3	17.45	22	22
A8	14	16	20	22	30	32、33	32、34
A9	2.3	4.2	4.3	6	5	7	5
B1	23.5	23.5	29	34	42	51	56.5
B2	7	8	8.5	12	15	18	20
B3	14.1	16	17.5	18.7	23.4	29	32
B4	2.4	3	3	3.3	3.6	4	4.5
B5	6	7	7.5	10	14	17	19
C1	70	80	90	110	142	170	190
C2	50	60	70	85	110	135	155
C3	70	80	90	110	142	170	190
C4	48	59.5	70	88	115	138	157.5
D1	8	12	12	12	12	12	18
D2	3.5	3.5	3.5	4.5	5.5	6.5	6.5
D3	64	74	84	102	132	158	180
D4	8	16	16	16	16	16	12
D5	3.3 M3xP0.5x6L	3.5 M3xP0.5x6L	3.5 M3xP0.5x6L	4.5 M4xP0.7x8L	5.5 M5xP0.8x8L	6.5 M6xP1.0x10L	8.5 M8xP1.25x10L
D6	44	54	62	77	100	122	140
E1	38	46	54	67	86	106	119
E2	1.5	1.5	2	2	2	2	2
E3	30	36	44	56	72	92	105
E4	2	2	2	2	2	2.5	3
Weight (g)	280	567	757	1,280	2,628	4,536	6,642

MODEL : DHF-AO

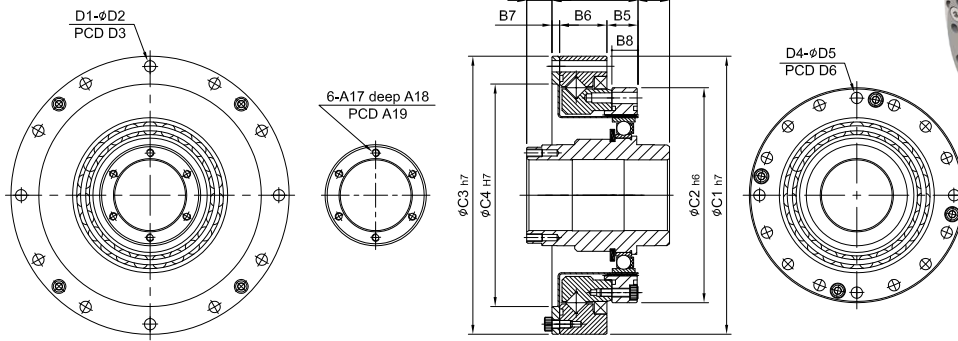

DHF14、DHF17

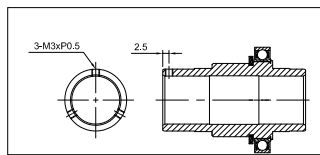

DHF20、DHF25

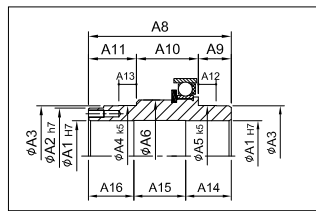

DHF32、DHF40、DHF45

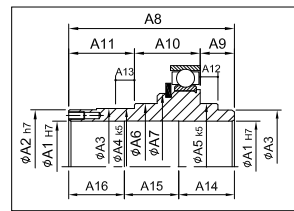

Code \ Model	14	17	20	25	32	40	45
A1	14	19	21	29	36	46	52
A2	20	25	30	38	45	59	64
A3	-	-	-	40	-	-	64.8
A4	20	25	30	40	45	60	65
A5	20	25	30	40	50	60	65
A6	24	29.5	34.5	44.3	50	65	70
A7	-	-	-	-	58	69	78
A8	53	56.5	51.5	55.5	65.5	79	85
A9	13	13	13	12.5	13.5	16	19
A10	20.5	24	20.5	24	26	35	36
A11	19.5	19.5	18	19	26	28	30
A12	7	7	7	7	7	10	10
A13	7	7	8	7	12	13	13
A14	18	18.5	17	18	22	27	29
A15	17	19.5	17.5	19.5	21.5	25	27
A16	18	18.5	17	18	22	27	29
A17	3-M3xP0.5	3-M3xP0.5	M3xP0.5	M3xP0.5	M3xP0.5	M4xP0.7	M4xP0.7
A18	-	-	6	6	6	8	8
A19	-	-	25.5	33.5	40.5	52	58
B1	53	56.5	51.5	56.5	68	80	86
B2	13.5	13.5	13	12.5	15	19	19
B3	23.5	27	29	34	41	48	53.5
B4	16	16	9.5	10	12	13	13.5
B5	7	8	8.5	12.3	14.6	15	17
B6	14.1	16	17.5	18.7	23.4	29	32
B7	2.4	3	3	3	3	4	4.5
B8	6	7	7.5	10.3	13.6	14	16
C1	70	80	90	110	142	170	190
C2	50	60	70	85	110	135	155
C3	70	80	90	110	142	170	190
C4	48	59.5	70	88	115	138	157.5
D1	8	12	12	12	12	12	18
D2	3.5	3.5	3.5	4.5	5.5	6.5	6.5
D3	64	74	84	102	132	158	180
D4	8	16	16	16	16	16	12
D5	3.3	3.5	3.5	4.5	5.5	6.5	8.5
D6	M3xP0.5x6L	M3xP0.5x6L	M3xP0.5x6L	M4xP0.7x8L	M5xP0.8x8L	M6xP1.0x10L	M8xP1.25x10L
Weight (g)	340	630	848	1,416	2,736	4,659	6,849

MODEL : DHF-O

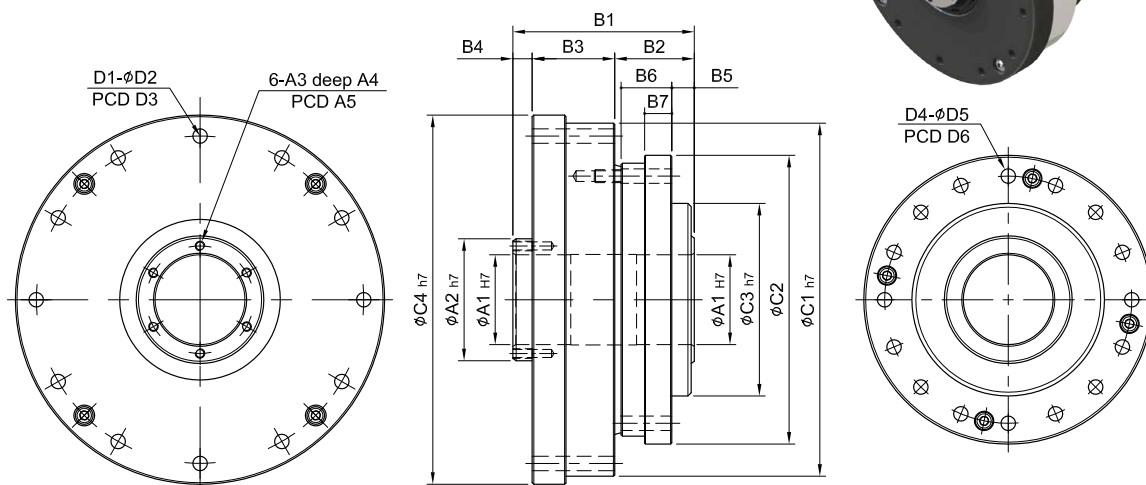

DHF14 · DHF17

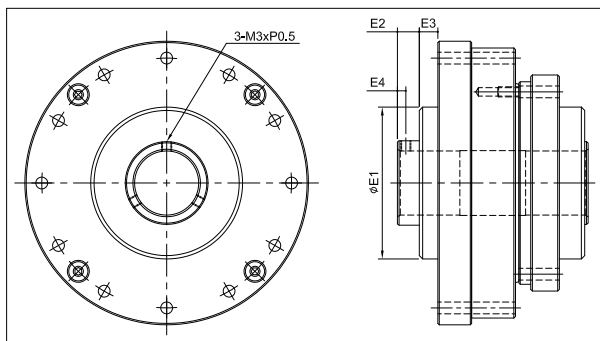

Code \ Model	14	17	20	25	32	40	45
A1	14	19	20	28	35	46	52
A2	20	25	30	38	45	59	64
A3	3-M3xP0.5	3-M3xP0.5	M3xP0.5	M3xP0.5	M3xP0.5	M4xP0.7	M4xP0.7
A4	-	-	6	6	6	8	8
A5	-	-	23.5	33.5	40.5	52	58
B1	53	56.5	51.5	56.5	68	80	86
B2	20.5	21.5	21.5	24.8	29.6	34	36
B3	20.5	23	25	25.7	31.4	38	42
B4	-	-	5	6	7	8	8
B5	8	8.5	7	7	6	8	8
B6	11.5	12	13.5	15.8	22.6	26	27
B7	8	8.5	9	8.5	12	16	16
C1	70	80	90	110	142	170	190
C2	50	64	75	90	115	140	160
C3	34	45	50	60	85	100	120
C4	74	84	95	115	147	175	195
D1	8	12	12	12	12	12	18
D2	3.5	3.5	3.5	4.5	5.5	6.5	6.5
D3	64	74	84	102	132	158	180
D4	8	16	16	16	16	16	12
D5	3.3 M3xP0.5x6L	3.5 M3xP0.5x6L	3.5 M3xP0.5x6L	4.5 M4xP0.7x8L	5.5 M5xP0.8x8L	6.5 M6xP1.0x10L	8.5 M8xP1.25x10L
D6	44	54	62	77	100	122	140
E1	36	45	-	-	-	-	-
E2	6.5	6.5	-	-	-	-	-
E3	5.5	5.5	-	-	-	-	-
E4	2.5	2.5	-	-	-	-	-
Weight (g)	470	808	1,168	1,709	3,500	5,983	8,254

MODEL : DHF-OR

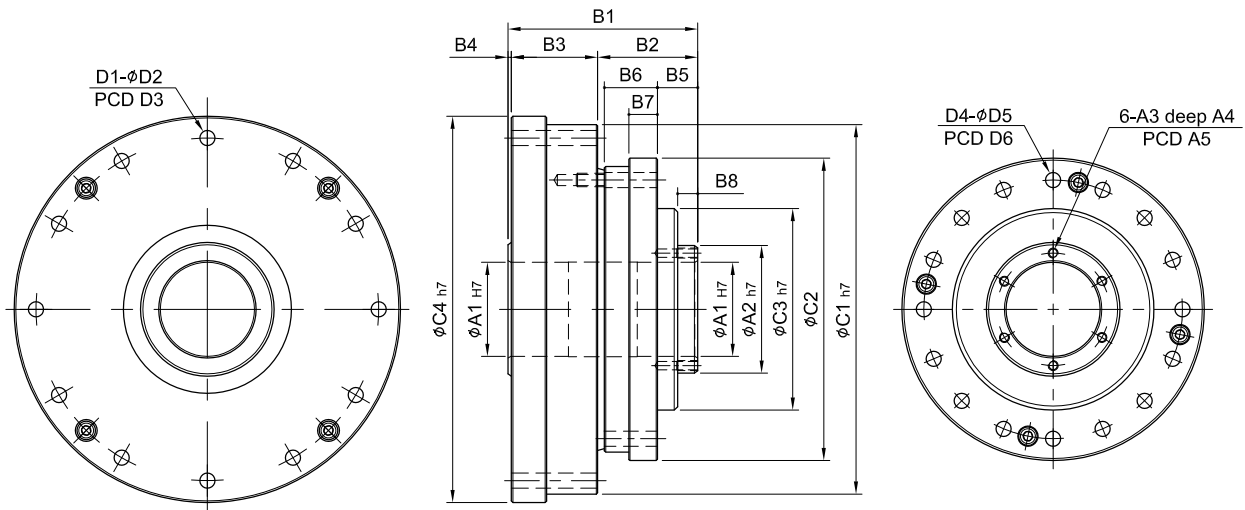

DHF14 · DHF17

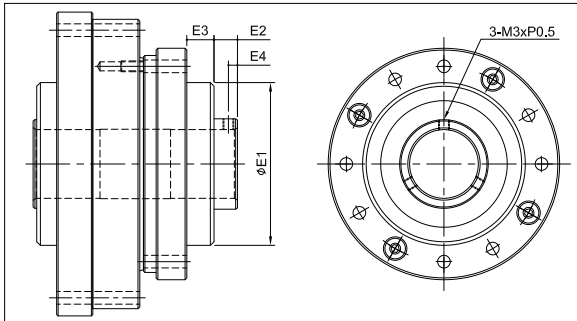

Code \ Model	14	17	20	25	32	40	45
A1	14	19	20	28	35	46	52
A2	20	25	30	38	45	59	64
A3	3-M3xP0.5	3-M3xP0.5	M3xP0.5	M3xP0.5	M3xP0.5	M4xP0.7	M4xP0.7
A4	-	-	6	6	6	8	8
A5	-	-	23.5	33.5	40.5	52	58
B1	53	56.5	51.5	56.5	65.5	79	85
B2	26.5	21.5	25.5	28.5	32.5	40	42
B3	20.5	23	25	26	32	38	42
B4	-	-	1	1	1	1	1
B5	14	8.5	11	11	11	14	14
B6	11.5	12	13.5	15.5	20.5	25	27
B7	8	8.5	9	8.5	9.5	13	12
B8			5	6	7	8	8
C1	70	80	90	110	142	170	190
C2	50	64	75	90	115	140	160
C3	34	45	50	60	85	100	120
C4	74	84	95	115	147	175	195
D1	8	12	12	12	12	12	18
D2	3.5	3.5	3.5	4.5	5.5	6.5	6.5
D3	64	74	84	102	132	158	180
D4	8	16	16	16	16	16	12
D5	3.3 M3xP0.5x6L	3.5 M3xP0.5x6L	3.5 M3xP0.5x6L	4.5 M4xP0.7x8L	5.5 M5xP0.8x8L	6.5 M6xP1.0x10L	8.5 M8xP1.25x10L
D6	44	54	62	77	100	122	140
D1	36	45	-	-	-	-	-
D2	6.5	6.5	-	-	-	-	-
D3	5.5	5.5	-	-	-	-	-
D4	2.5	2.5	-	-	-	-	-
Weight (g)							

MODEL : DHF-S

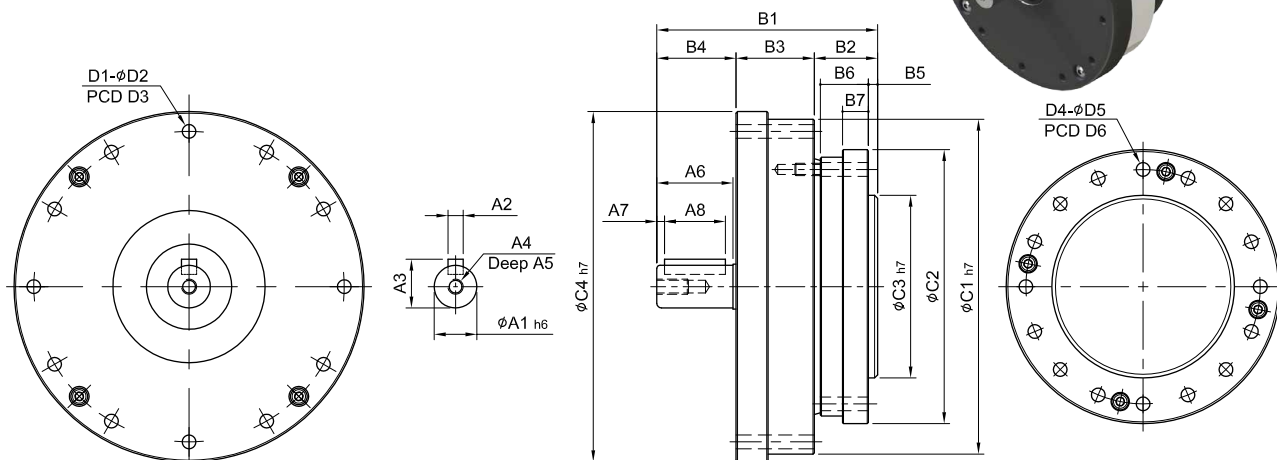

DHF14 · DHF17

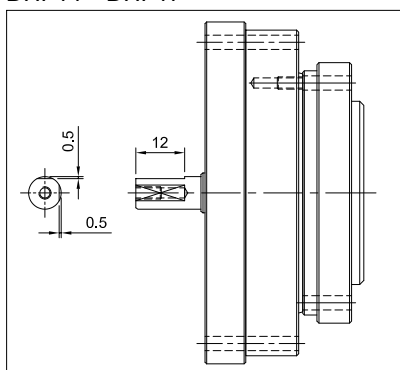

Code \ Model	14	17	20	25	32	40	45
A1	8	8	10	14	14	19	19
A2	-	-	3	5	5	6	6
A3	-	-	11.2	16	16	21.5	21.5
A4	M3xP0.5	M3xP0.5	M3xP0.5	M5xP0.8	M5xP0.8	M6xP1.0	M6xP1.0
A5	6	6	6	10	10	12	12
A6	14	16	20	25	25	30	30
A7	-	-	2.5	2.5	2.5	2.5	2.5
A8	-	-	15	20	20	25	25
B1	50.5	56	63.5	72.5	84.5	100	108
B2	15	16	17.5	20.8	27.1	31	35
B3	20.5	23	25	25.7	31.4	38	42
B4	15	17	21	26	26	31	31
B5	2.5	3	3	3	4.5	5	7
B6	11.5	12	13.5	15.8	21.6	26	27
B7	8	8.5	9	8.5	11	16	16
C1	70	80	90	110	142	170	190
C2	54	64	75	90	115	140	160
C3	36	45	50	60	85	100	120
C4	74	84	95	115	147	175	195
D1	8	12	12	12	12	12	18
D2	3.5	3.5	3.5	4.5	5.5	6.5	6.5
D3	64	74	84	102	132	158	180
D4	8	16	16	16	16	16	12
D5	3.3	3.5	3.5	4.5	5.5	6.5	8.5
D6	M3xP0.5x6L	M3xP0.5x6L	M3xP0.5x6L	M4xP0.7x8L	M5xP0.8x8L	M6xP1.0x10L	M8xP1.25x10L
Weight (g)	450	763	1,057	1,675	3,458	5,906	8,463

諧波減速機 DSF-MC 與馬達安裝指南 ROBONICDRIVE DSF-MC and Motor Mounting Instructions



核對馬達型號與減速機規格是否正確。
並將配合面擦拭乾淨。
Confirm the motor, and gearbox size.
Clean up the mounting surface.

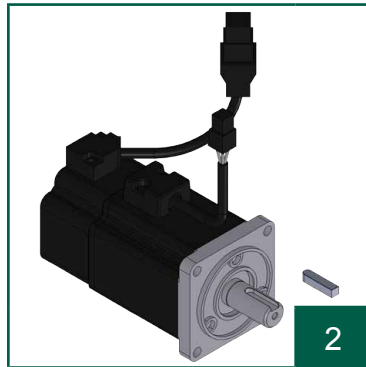

請使用帶油封之電機，避免潤滑脂洩漏至電機。
Please use a motor with oil seal to prevent grease leaking to the motor..

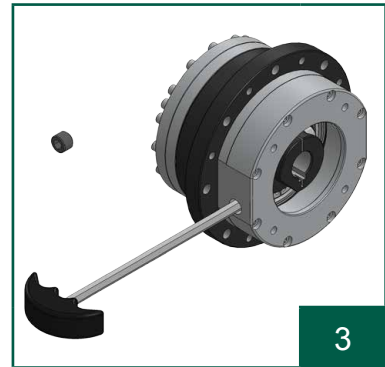

取出塞頭，使用六角板手將迫緊環螺絲鬆開。並將螺絲對準孔位。
Remove the plug on the adapter plate.
Rotate the set collar till the bolt is line up.

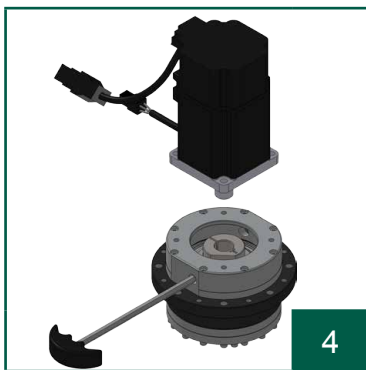

將馬達垂直裝入減速機。
Put the motor into the gearbox vertically.

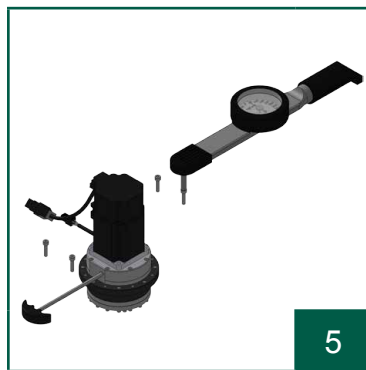

依序使用扭力板手鎖上外六角螺絲。
Tighten the mounting bolt in 1~4 order with torque wrench.

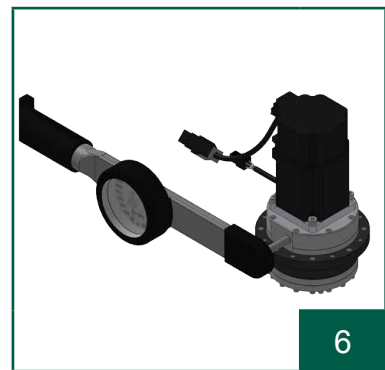

使用扭力板手將迫緊環螺絲鎖緊。
Tighten the set collar bolt with torque wrench.

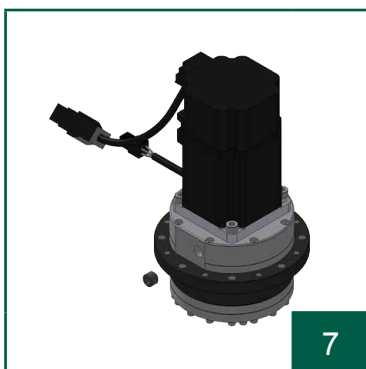

裝回塞頭。
Tighten back the screw plug.

- 務必先鎖緊馬達，才能鎖緊馬達軸心迫緊環。
To be sure to tighten motor first and then to tighten the set collar on motor shaft.
- 請依步驟順序組裝，尤其步驟 5、6 不可顛倒。
Please assembly in order according to above steps, especially for step 5 and step 6.

MODEL : DSS-14

RATIO : 100

精密旋轉平台 High Precision Rotary Reducer

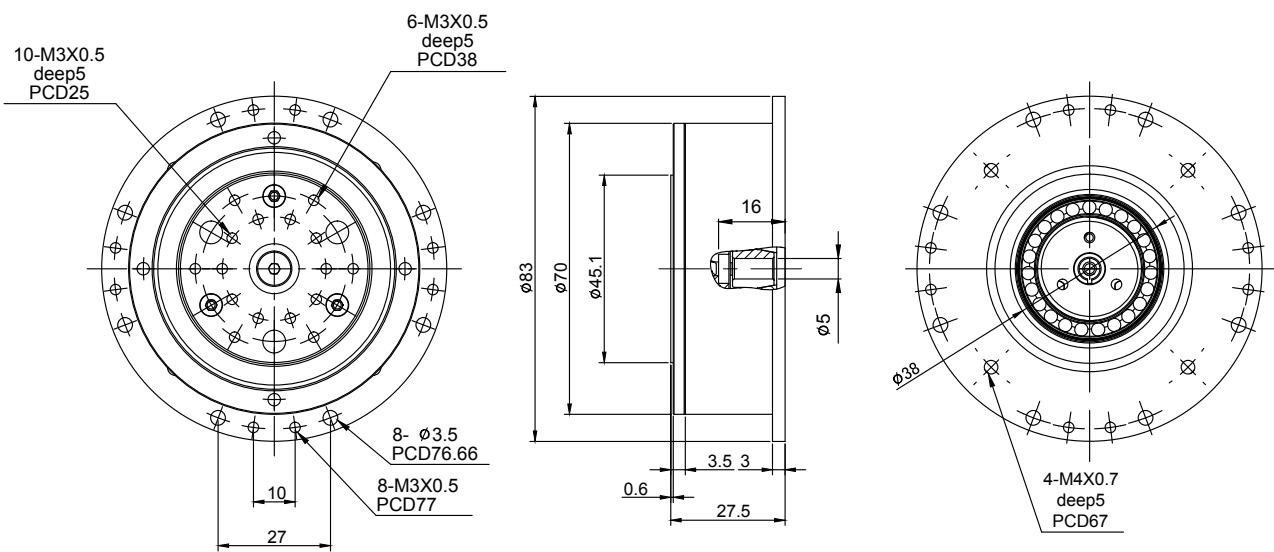
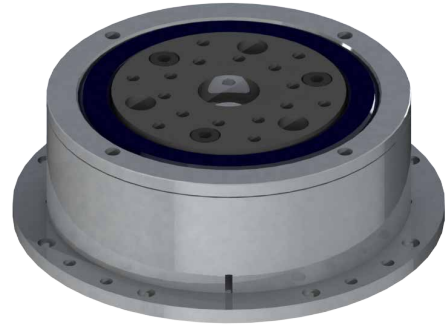

產品特性 Features

- 額定輸出扭矩 Nominal Output Torque : 9Nm
- 容許載重 Permissible Thrust Load : 100N
- 容許慣量載重 Permissible Moment Load : 10Nm



CYKODRIVE

高精密擺線減速機

CYKODRIVE Cycloidal Reducers



- CYKODRIVE 系列減速機是在擺線針輪傳動基礎上發展起來的一種傳動。
The CYKODRIVE series reducer is a type of transmission developed on the basis of cycloidal pinwheel transmission.
- 由漸開線圓柱齒輪行星減速機構和擺線針輪行星減速機構二部份構成。
It consists of two parts: the involute cylindrical gear planetary reduction mechanism and the cycloidal pinion planetary reduction mechanism.
- 漸開線行星齒輪與凸輪軸連成一體，作為擺線針輪傳動部分的輸入。
The involute planetary gear is integrated with the camshaft as an input to the cycloidal pinion drive section.
- 凸輪軸帶動擺線齒輪做偏心運動。凸輪軸向順時針方向旋轉 1 週，擺線齒輪將沿逆時針方向移動 1 個齒。
The camshaft drives the cycloidal gear to perform eccentric motion. The cam shaft rotates clockwise for 1 turn, and the cycloidal gear moves 1 tooth in the counterclockwise direction.

機種型號表示 Indication of Model Numbers

RS	N	20	—	41	—	P0	—	MOTOR
減速機機型 Type	入力表示 Input	型號 Model		速比 Ratio		背隙等級 Backlash Class		馬達型號 Motor Type
RS RD RC	E: 組件式 Component Type N: 入力法蘭 Motor Flange Type S: 入力軸式 Input Shaft Type L: 入力直交	6 20 40 80 110 160 320		41 ~ 171 Note 1		Ps ≤ 1 arcmin P0 ≤ 3 arcmin P1 ≤ 5 arcmin		

[Note 1] 有關各個機型型號的速比，請參見尺寸頁面。
See the dimension page for gear ratio details.

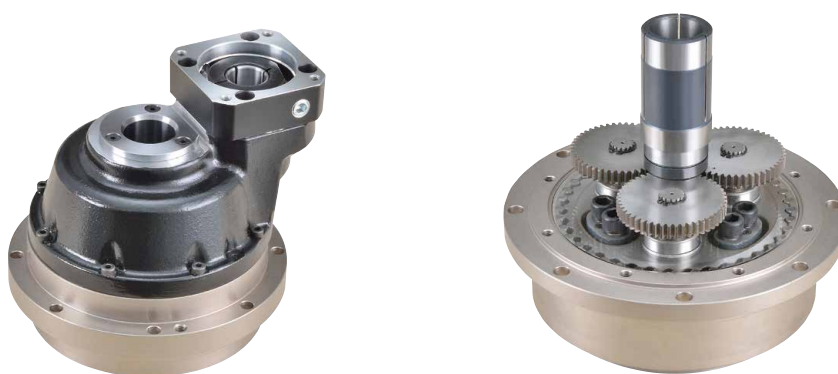

旋轉方向與速比如下圖所示，請選擇最佳使用方法：
The housing is fixed, and the output shaft drive:

- ① 減速機箱體外殼固定，由出力軸輸出的情況：
出力軸的旋轉方向與輸入軸的旋轉方向相同。
減速比等於型錄上的公稱減速比。
The rotation direction of the output shaft is the same as the input shaft.
The reduction ratio is equal to the reduction ratio on the catalog.

- ② 出力軸固定，減速機箱體外殼輸出的情況：
減速機箱體外殼的旋轉方向與輸入軸的旋轉方向相反。
減速比等於型錄上的減速比減 1。
The output shaft is fixed, and the housing drive:
The rotation direction of the housing is the opposite to the input shaft.
The reduction ratio is calculated the reduction ratio on the catalog minus 1.

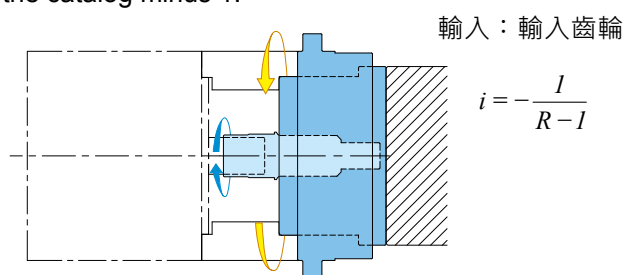
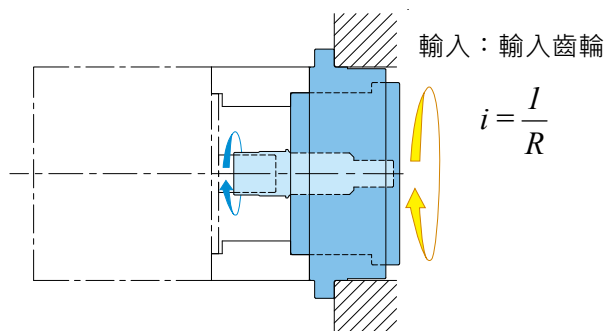

產品樣式選擇 Selection of Type

		入力形式 Input Type			
		E 組件式 Component Type	N 入力法蘭 Motor Flange Type	S 入力軸式 Input Shaft Type	L 入力直交 Input Right Angle
出力形式	RS				
		RSE	RSN	RSS	RSL
	RD				
	RDE	RDN	RDS	RDL	
RC 出力中空軸 Hollow Output Shaft					
	RCE	RCN	RCS	RCL	

產品特性 Characteristic

- 高可靠性、高剛度、高精度、大扭矩
 1. 最佳化的擺線齒型設計，扭曲剛度非常大。
 2. 兩個擺線輪設計，多齒嚙合增加強度。
 3. 採用雙支撐的斜角滾珠軸承並加大軸承跨距，增加出力端剛性。
 4. 即使施加高達額定轉矩 5 倍的轉矩時，產品也不會損壞。
 5. 高精密的加工技術，使得產品齒隙小 (<1 arcmin)，運轉效率高。
- 追求簡單使用
 1. 已封入潤滑脂，防護等級 IP65，免更換及保護。
 2. 採用筒夾式的鎖緊機構和及這適用於各廠牌的馬達法蘭，使馬達的安裝非常簡單。

- High reliability, high rigidity, high precision, high torque
 1. The optimized cycloidal tooth design makes it very high twisting stiffness.
 2. Dual cycloidal wheels, multi-toothed meshing for increased strength.
 3. Double-supported angular contact ball bearings are used to increase the bearing span and increase the rigidity of the output end.
 4. Even the torque up to 5 times rated torque, the product will not be damaged.
 5. High-precision machining technology makes the product have small backlash (<1 arcmin) and high operating efficiency.
- Easy installation and maintenance
 1. Grease is sealed, protection class IP65. No need to replace the grease.
 2. The motor flange is ready for each brand and a collet-type locking mechanism makes the installation of motor very easy.

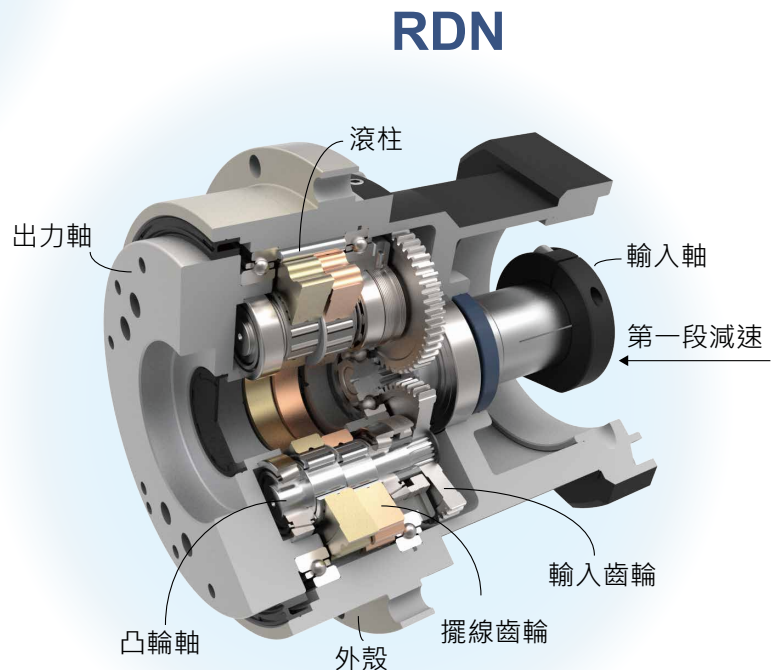
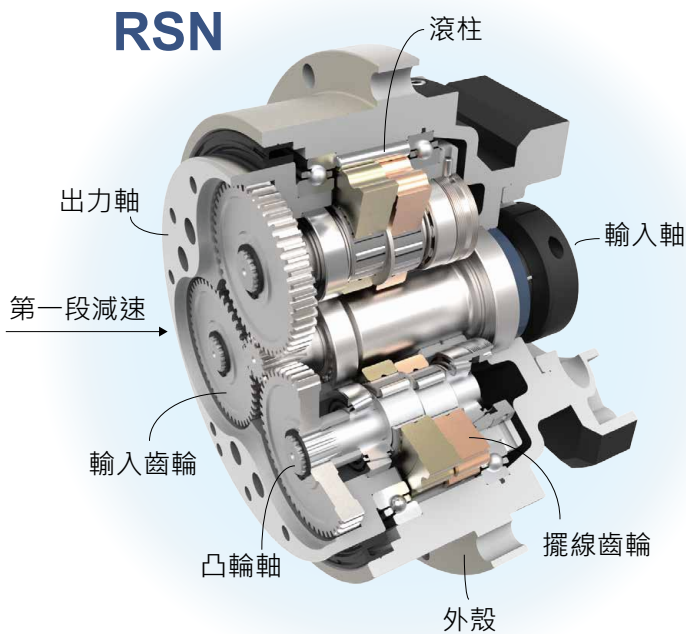



RSE

高精密擺線減速機

MODEL : RSE6

RATIO : 41、61、81、121

Unit: mm

Model Code	A Type
A	#6802
B	Ø15 ^{-0.01} / _{-0.02}
C	13
D	21.5

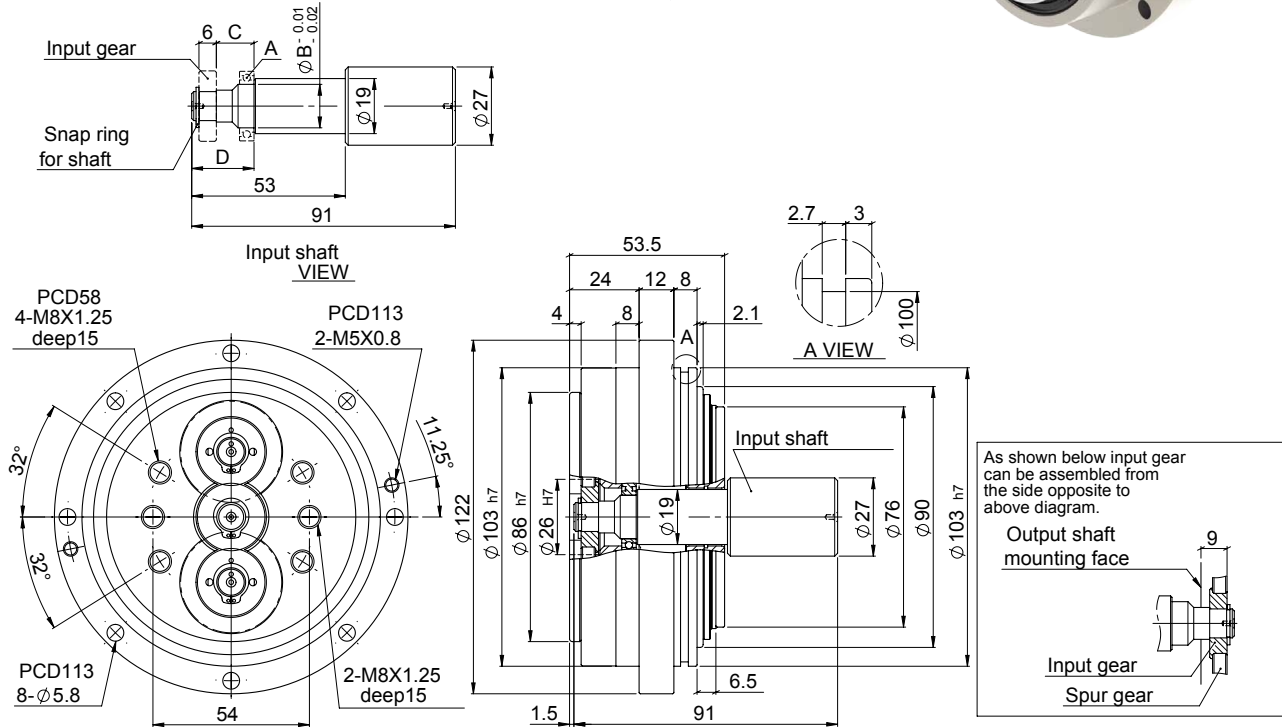

特性 Characteristic	代號	單位 Unit	RSE6
輸出平台支撐軸承 / Output Table Supporting Bearing			斜角滾珠軸承 Angular Contact Ball Bearing
額定輸出扭矩 / Rated Output Torque		Nm	60
最大輸出扭矩 / Max. Output Torque 急停扭矩 / Emergency Stop Torque	T_{2NOT}	Nm	5 倍額定輸出扭矩 5 Time of Rated Output Torque
最大加速力矩 / Max. Acceleration Torque	T_{2B}	Nm	2 倍額定輸出力矩 2 Times of Rated Output Torque
慣性慣量 / Inertia Moment		kg.m ²	1.15 x 10 ⁻⁴
額定出力轉速 / Rated Output Speed		rpm	15
最大輸出轉速 / Max. Output Speed		rpm	55
容許輸入轉速 / Permissible Input Speed		rpm	3,000
背隙 / Backlash Ps	J_i	arcmin	≤ 2
背隙 / Backlash P0	J_i	arcmin	≤ 4
背隙 / Backlash P1	J_i	arcmin	≤ 6
容許徑向力 / Max. Radial Force	F_{2rB}	N	2,100
容許軸向力 / Max. Axial Force	F_{2aB}	N	1,500
額定壽命 / Rated Life	L_H	hr	S5 周期運轉 : >6,000 (S1 連續運轉 : >3,000 hrs) S5 Cycle Operation: >6,000 (S1 Continuous Operation: >3,000 hrs)
扭轉剛性 / Torsional Rigidity		Nm/arcmin	50
效率 / Efficiency	η	%	≥ 85
重量 / Weight		kg	2.8

MODEL : RSE20

RATIO : 41、61、81、121、161

Unit: mm

Model Code	A Type
A	#6902
B	Ø15 ^{-0.01} / _{-0.02}
C	16.5
D	26

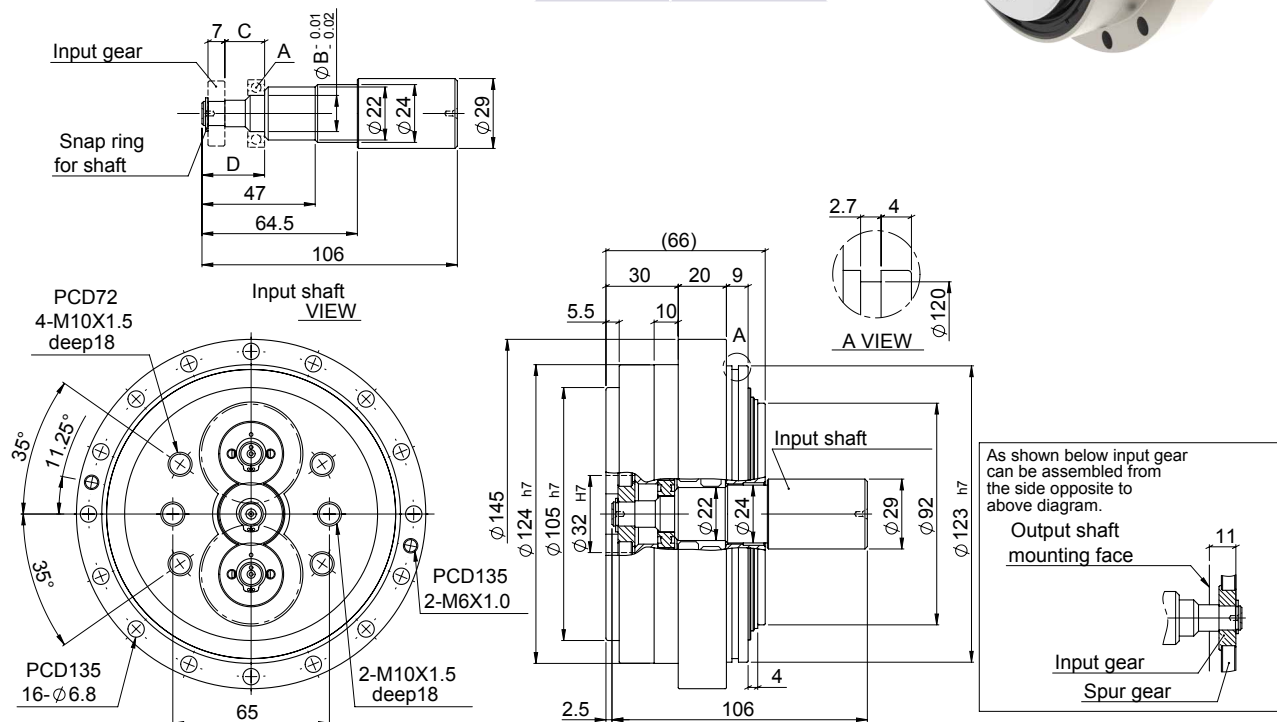

特性 Characteristic	代號	單位 Unit	RSE20
輸出平台支撐軸承 / Output Table Supporting Bearing			斜角滾珠軸承 Angular Contact Ball Bearing
額定輸出扭矩 / Rated Output Torque		Nm	200
最大輸出扭矩 / Max. Output Torque 急停扭矩 / Emergency Stop Torque	T_{2NOT}	Nm	5 倍額定輸出扭矩 5 Time of Rated Output Torque
最大加速力矩 / Max. Acceleration Torque	T_{2B}	Nm	2.5 倍額定輸出力矩 2.5 Times of Rated Output Torque
慣性慣量 / Inertia Moment		kg.m ²	2×10^{-4}
額定出力轉速 / Rated Output Speed		rpm	15
最大輸出轉速 / Max. Output Speed		rpm	50
容許輸入轉速 / Permissible Input Speed		rpm	3,000
背隙 / Backlash Ps	J_i	arcmin	≤ 1
背隙 / Backlash P0	J_i	arcmin	≤ 3
背隙 / Backlash P1	J_i	arcmin	≤ 5
容許徑向力 / Max. Radial Force	F_{2rB}	N	6,500
容許軸向力 / Max. Axial Force	F_{2aB}	N	4,300
額定壽命 / Rated Life	L_H	hr	S5 周期運轉 : >6,000 (S1 連續運轉 : >3,000 hrs) S5 Cycle Operation: >6,000 (S1 Continuous Operation: >3,000 hrs)
扭轉剛性 / Torsional Rigidity		Nm/arcmin	70
效率 / Efficiency	η	%	≥ 85
重量 / Weight		kg	5.1

MODEL : RSE40

RATIO : 41、61、81、121、161

Unit: mm

Model Code	A Type
A	#6904
B	Ø20 ^{-0.01} / _{-0.02}
C	20
D	30.5

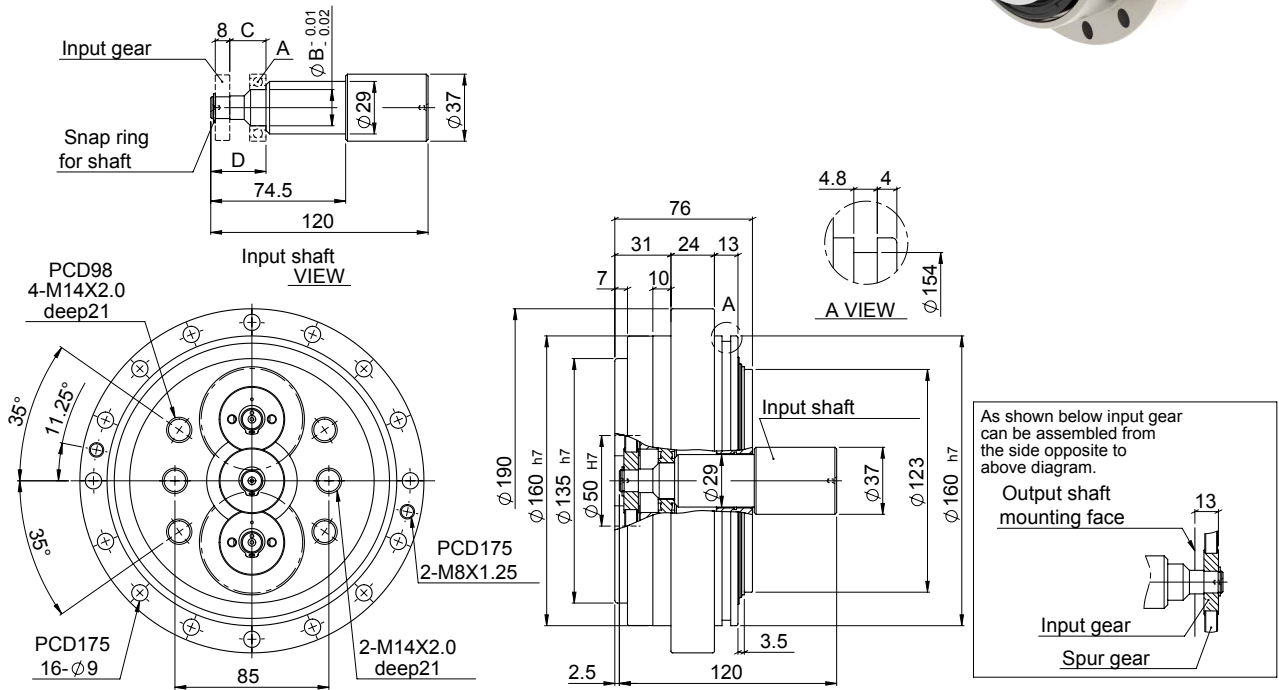

特性 Characteristic	代號	單位 Unit	RSE40
輸出平台支撐軸承 / Output Table Supporting Bearing			斜角滾珠軸承 Angular Contact Ball Bearing
額定輸出扭矩 / Rated Output Torque		Nm	400
最大輸出扭矩 / Max. Output Torque 急停扭矩 / Emergency Stop Torque	T_{2NOT}	Nm	5 倍額定輸出扭矩 5 Time of Rated Output Torque
最大加速力矩 / Max. Acceleration Torque	T_{2B}	Nm	2.5 倍額定輸出力矩 2.5 Times of Rated Output Torque
慣性慣量 / Inertia Moment		kg.m ²	5×10^{-4}
額定出力轉速 / Rated Output Speed		rpm	15
最大輸出轉速 / Max. Output Speed		rpm	45
容許輸入轉速 / Permissible Input Speed		rpm	3,000
背隙 / Backlash Ps	J_i	arcmin	≤ 1
背隙 / Backlash P0	J_i	arcmin	≤ 3
背隙 / Backlash P1	J_i	arcmin	≤ 5
容許徑向力 / Max. Radial Force	F_{2rB}	N	8,600
容許軸向力 / Max. Axial Force	F_{2aB}	N	5,700
額定壽命 / Rated Life	L_H	hr	S5 周期運轉 : >6,000 (S1 連續運轉 : >3,000 hrs) S5 Cycle Operation: >6,000 (S1 Continuous Operation: >3,000 hrs)
扭轉剛性 / Torsional Rigidity		Nm/arcmin	100
效率 / Efficiency	η	%	≥ 85
重量 / Weight		kg	9.7

MODEL : RSE80

RATIO : 45、66、81、101、171

Unit: mm

Model Code	A Type	B Type (1/101)
A	#6004	#6905
B	Ø20 ^{-0.01/-0.02}	Ø25 ^{-0.01/-0.02}
C	21	18
D	35.5	32.5

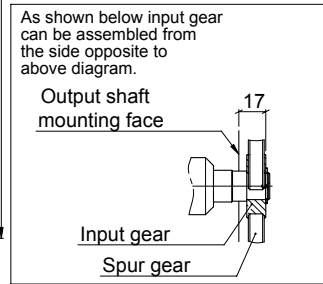
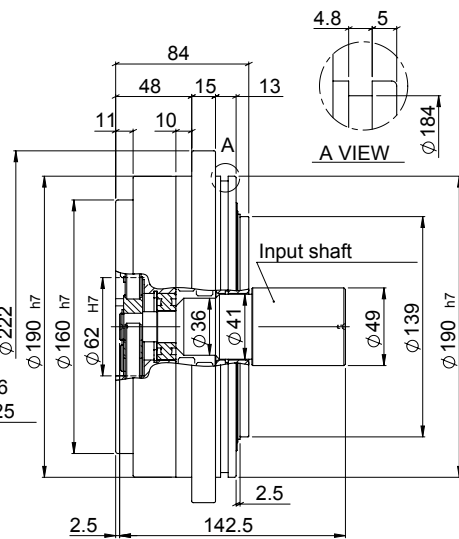
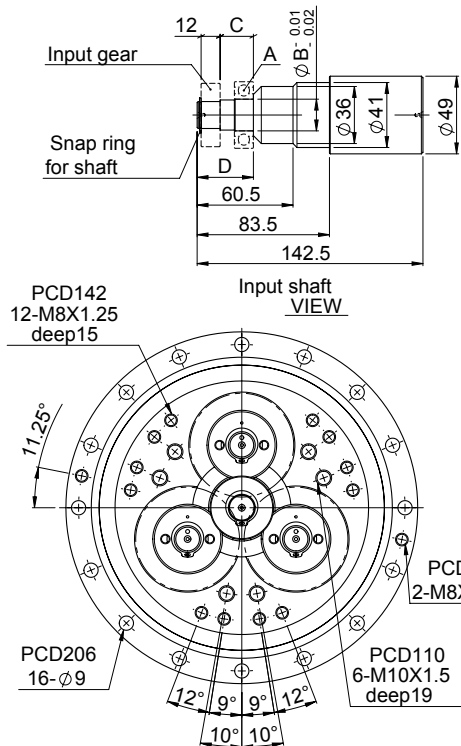

特性 Characteristic	代號	單位 Unit	RSE80
輸出平台支撐軸承 / Output Table Supporting Bearing			斜角滾珠軸承 Angular Contact Ball Bearing
額定輸出扭矩 / Rated Output Torque		Nm	800
最大輸出扭矩 / Max. Output Torque 急停扭矩 / Emergency Stop Torque	T_{2NOT}	Nm	5 倍額定輸出扭矩 5 Time of Rated Output Torque
最大加速力矩 / Max. Acceleration Torque	T_{2B}	Nm	2.5 倍額定輸出力矩 2.5 Times of Rated Output Torque
慣性慣量 / Inertia Moment		kg.m ²	9 x 10 ⁻⁴
額定出力轉速 / Rated Output Speed		rpm	15
最大輸出轉速 / Max. Output Speed		rpm	42
容許輸入轉速 / Permissible Input Speed		rpm	3,000
背隙 / Backlash Ps	J_i	arcmin	≤ 1
背隙 / Backlash P0	J_i	arcmin	≤ 3
背隙 / Backlash P1	J_i	arcmin	≤ 5
容許徑向力 / Max. Radial Force	F_{2rB}	N	12,500
容許軸向力 / Max. Axial Force	F_{2aB}	N	8,200
額定壽命 / Rated Life	L_H	hr	S5 周期運轉 : >6,000 (S1 連續運轉 : >3,000 hrs) S5 Cycle Operation: >6,000 (S1 Continuous Operation: >3,000 hrs)
扭轉剛性 / Torsional Rigidity		Nm/arcmin	150
效率 / Efficiency	η	%	≥ 85
重量 / Weight		kg	15.5

MODEL : RSE110

RATIO : 41、61、81、121、161

Unit: mm

Model Code	A Type	B Type (1/121)
A	#6005	#6906
B	Ø25 ^{-0.01/-0.02}	Ø30 ^{-0.01/-0.02}
C	24.5	21.5
D	39	36

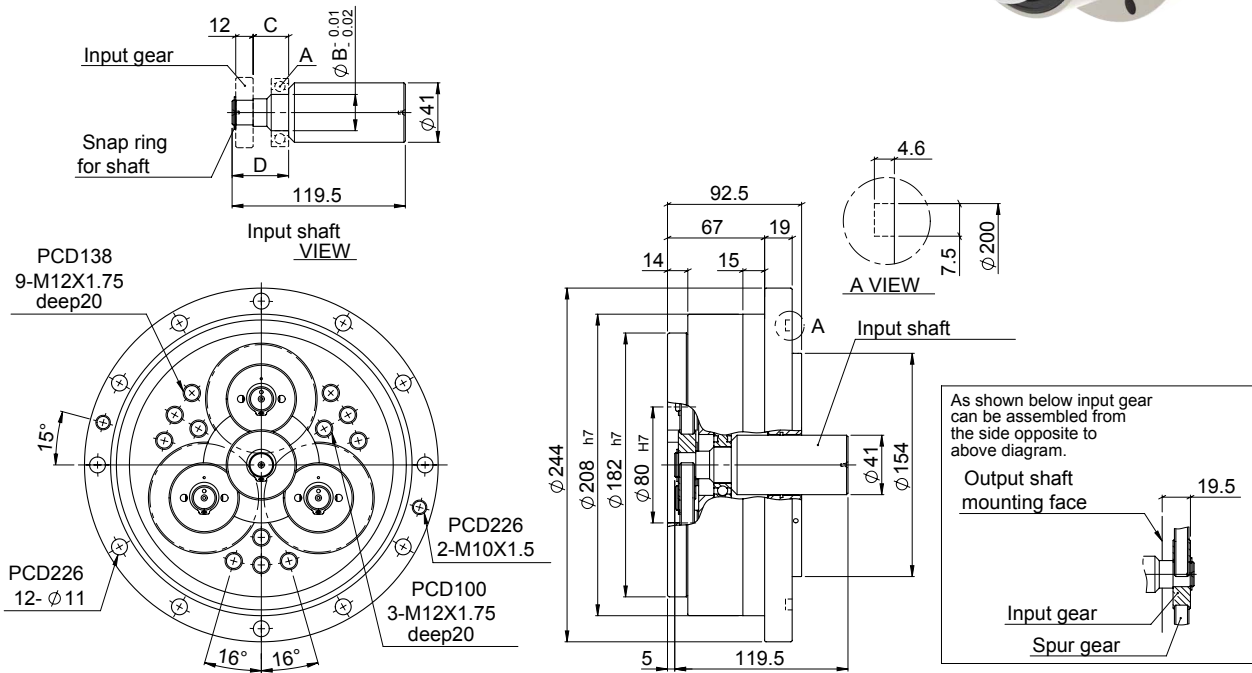

特性 Characteristic	代號	單位 Unit	RSE110
輸出平台支撐軸承 / Output Table Supporting Bearing			斜角滾珠軸承 Angular Contact Ball Bearing
額定輸出扭矩 / Rated Output Torque		Nm	1,100
最大輸出扭矩 / Max. Output Torque 急停扭矩 / Emergency Stop Torque	T_{2NOT}	Nm	5 倍額定輸出扭矩 5 Time of Rated Output Torque
最大加速力矩 / Max. Acceleration Torque	T_{2B}	Nm	2.5 倍額定輸出力矩 2.5 Times of Rated Output Torque
慣性慣量 / Inertia Moment		kg.m ²	15 x 10 ⁻⁴
額定出力轉速 / Rated Output Speed		rpm	15
最大輸出轉速 / Max. Output Speed		rpm	35
容許輸入轉速 / Permissible Input Speed		rpm	3,000
背隙 / Backlash Ps	J_i	arcmin	≤ 1
背隙 / Backlash P0	J_i	arcmin	≤ 3
背隙 / Backlash P1	J_i	arcmin	≤ 5
容許徑向力 / Max. Radial Force	F_{2rB}	N	16,000
容許軸向力 / Max. Axial Force	F_{2aB}	N	12,000
額定壽命 / Rated Life	L_H	hr	S5 周期運轉 : >6,000 (S1 連續運轉 : >3,000 hrs) S5 Cycle Operation: >6,000 (S1 Continuous Operation: >3,000 hrs)
扭轉剛性 / Torsional Rigidity		Nm/arcmin	210
效率 / Efficiency	η	%	≥ 85
重量 / Weight		kg	20.5

MODEL : RSE160

RATIO : 41、61、81、121、161

Unit: mm

Model Code	A Type	B Type (1/121)
A	#6006	#6907
B	Ø30 ^{-0.01/-0.02}	Ø35 ^{-0.01/-0.02}
C	26.5	23.5
D	43.5	40.5

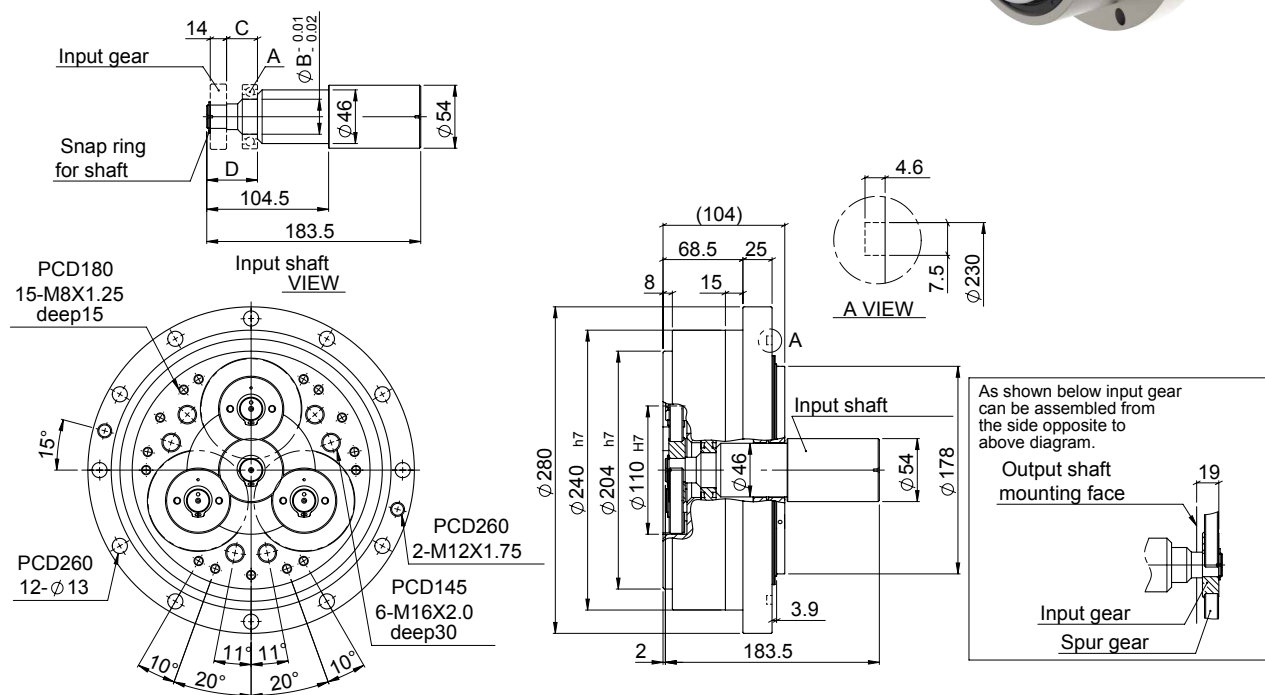

特性 Characteristic	代號	單位 Unit	RSE160
輸出平台支撐軸承 / Output Table Supporting Bearing			斜角滾珠軸承 Angular Contact Ball Bearing
額定輸出扭矩 / Rated Output Torque		Nm	1,600
最大輸出扭矩 / Max. Output Torque 急停扭矩 / Emergency Stop Torque	T_{2NOT}	Nm	5 倍額定輸出扭矩 5 Time of Rated Output Torque
最大加速力矩 / Max. Acceleration Torque	T_{2B}	Nm	2.5 倍額定輸出力矩 2.5 Times of Rated Output Torque
慣性慣量 / Inertia Moment		kg.m ²	25 x 10 ⁻⁴
額定出力轉速 / Rated Output Speed		rpm	15
最大輸出轉速 / Max. Output Speed		rpm	27
容許輸入轉速 / Permissible Input Speed		rpm	3,000
背隙 / Backlash Ps	J_i	arcmin	≤ 1
背隙 / Backlash P0	J_i	arcmin	≤ 3
背隙 / Backlash P1	J_i	arcmin	≤ 5
容許徑向力 / Max. Radial Force	F_{2rB}	N	19,000
容許軸向力 / Max. Axial Force	F_{2aB}	N	15,000
額定壽命 / Rated Life	L_H	hr	S5 周期運轉 : >6,000 (S1 連續運轉 : >3,000 hrs) S5 Cycle Operation: >6,000 (S1 Continuous Operation: >3,000 hrs)
扭轉剛性 / Torsional Rigidity		Nm/arcmin	300
效率 / Efficiency	η	%	≥ 85
重量 / Weight		kg	31.7

MODEL : RSE320

RATIO : 41、61、81、121、161

Unit: mm

Model Code	A Type
A	#6007
B	Ø35 ^{-0.01} _{-0.02}
C	32
D	51

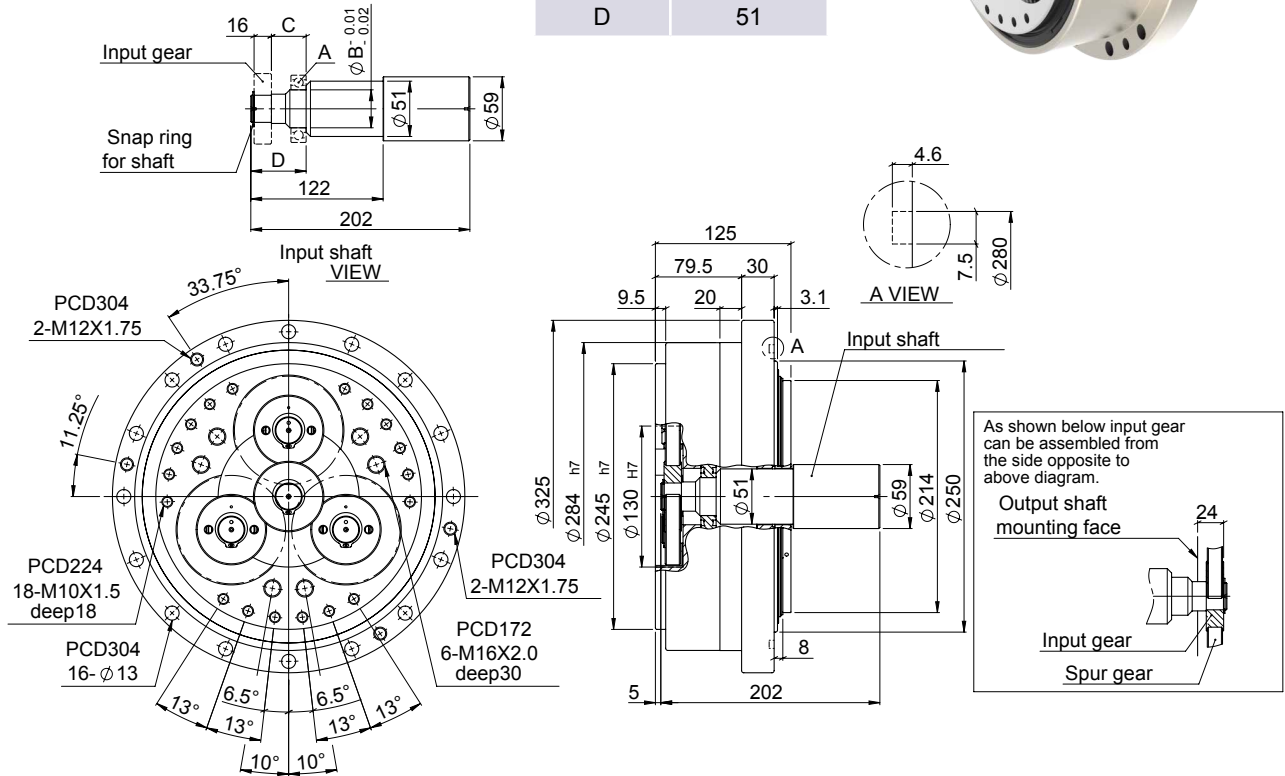

特性 Characteristic	代號	單位 Unit	RSE320
輸出平台支撐軸承 / Output Table Supporting Bearing			斜角滾珠軸承 Angular Contact Ball Bearing
額定輸出扭矩 / Rated Output Torque		Nm	3,200
最大輸出扭矩 / Max. Output Torque 急停扭矩 / Emergency Stop Torque	T_{2NOT}	Nm	5 倍額定輸出扭矩 5 Time of Rated Output Torque
最大加速力矩 / Max. Acceleration Torque	T_{2B}	Nm	2.5 倍額定輸出力矩 2.5 Times of Rated Output Torque
慣性慣量 / Inertia Moment		kg.m ²	32 x 10 ⁻⁴
額定出力轉速 / Rated Output Speed		rpm	15
最大輸出轉速 / Max. Output Speed		rpm	21
容許輸入轉速 / Permissible Input Speed		rpm	3,000
背隙 / Backlash Ps	J_i	arcmin	≤ 1
背隙 / Backlash P0	J_i	arcmin	≤ 3
背隙 / Backlash P1	J_i	arcmin	≤ 5
容許徑向力 / Max. Radial Force	F_{2rB}	N	25,300
容許軸向力 / Max. Axial Force	F_{2aB}	N	20,000
額定壽命 / Rated Life	L_H	hr	S5 周期運轉 : >6,000 (S1 連續運轉 : >3,000 hrs) S5 Cycle Operation: >6,000 (S1 Continuous Operation: >3,000 hrs)
扭轉剛性 / Torsional Rigidity		Nm/arcmin	980
效率 / Efficiency	η	%	≥ 85
重量 / Weight		kg	50.8



RSN

高精密擺線減速機

MODEL : RSN6

RATIO : 41、61、81、121

Unit: mm

Model Code	RSN6
A1	70、75、90
A2	M4、M5、M6
A3	50、60、70
A4	64、70、80

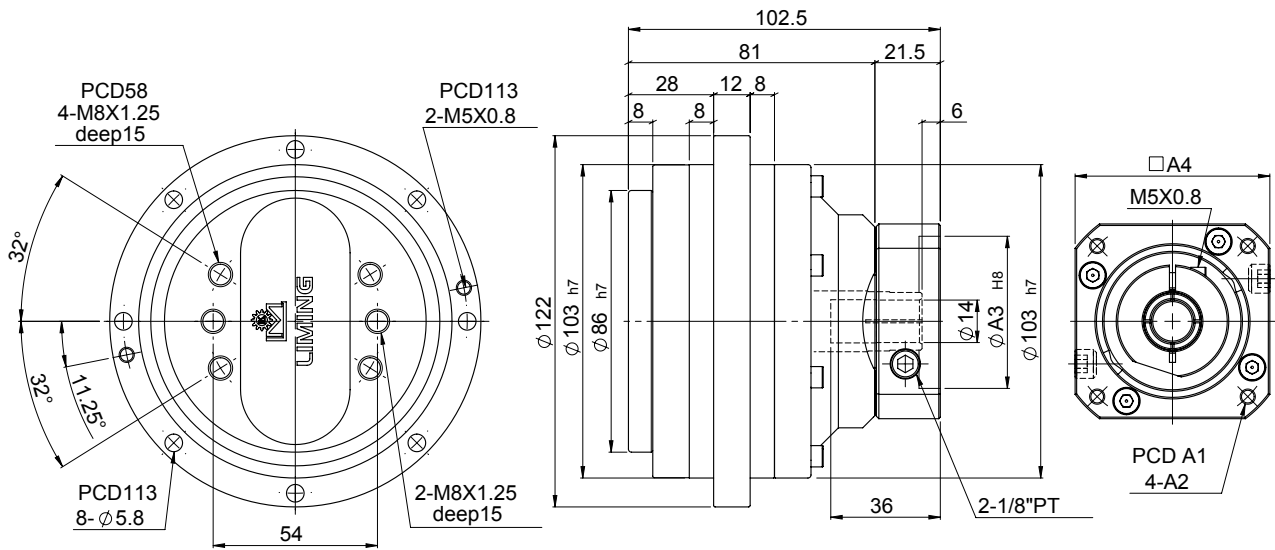

特性 Characteristic	代號	單位 Unit	RSN6
輸出平台支撐軸承 / Output Table Supporting Bearing			斜角滾珠軸承 Angular Contact Ball Bearing
額定輸出扭矩 / Rated Output Torque		Nm	60
最大輸出扭矩 / Max. Output Torque 急停扭矩 / Emergency Stop Torque	T_{2NOT}	Nm	5 倍額定輸出扭矩 5 Time of Rated Output Torque
最大加速力矩 / Max. Acceleration Torque	T_{2B}	Nm	2 倍額定輸出力矩 2 Times of Rated Output Torque
慣性慣量 / Inertia Moment		kg.m ²	1.15 x 10 ⁻⁴
額定出力轉速 / Rated Output Speed		rpm	15
最大輸出轉速 / Max. Output Speed		rpm	55
容許輸入轉速 / Permissible Input Speed		rpm	3,000
背隙 / Backlash Ps	J_i	arcmin	≤ 2
背隙 / Backlash P0	J_i	arcmin	≤ 4
背隙 / Backlash P1	J_i	arcmin	≤ 6
容許徑向力 / Max. Radial Force	F_{2rB}	N	2,100
容許軸向力 / Max. Axial Force	F_{2aB}	N	1,500
額定壽命 / Rated Life	L_H	hr	S5 周期運轉 : >6,000 (S1 連續運轉 : >3,000 hrs) S5 Cycle Operation: >6,000 (S1 Continuous Operation: >3,000 hrs)
扭轉剛性 / Torsional Rigidity		Nm/arcmin	50
效率 / Efficiency	η	%	≥ 85
全合成潤滑油脂 / Synthetic Grease		g	100
重量 / Weight		kg	3.19

MODEL : RSN20

RATIO : 41、61、81、121、161

Unit: mm

Model Code	RSN20
A1	70、75、90
A2	M4、M5、M6
A3	50、60、70
A4	64、70、80
A5	14、19
A6	36、46

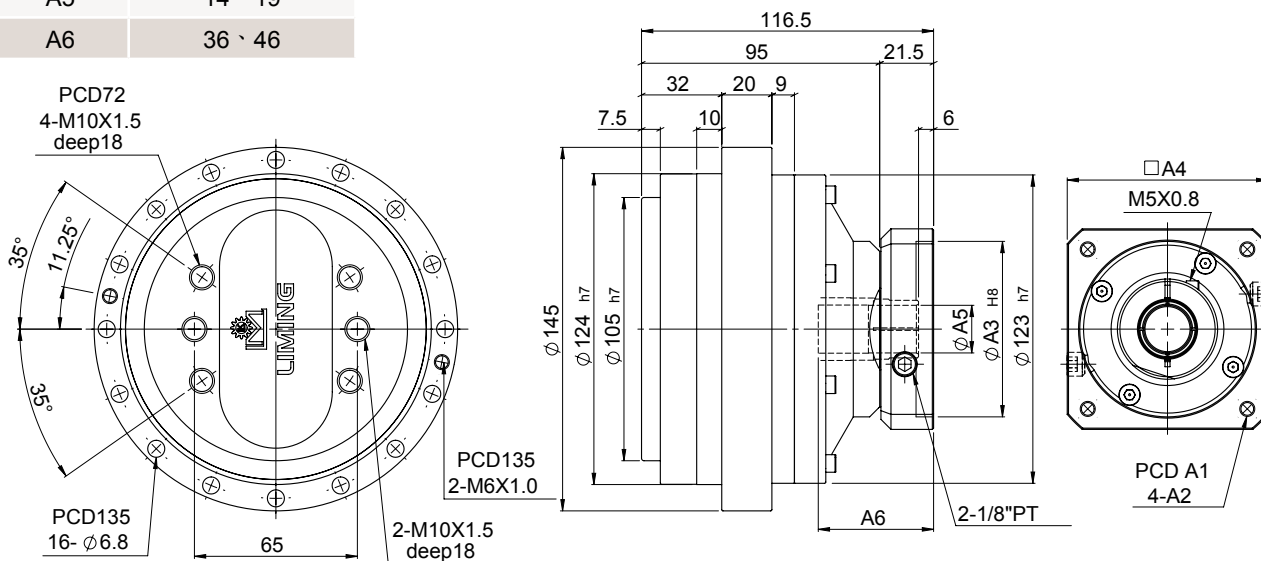
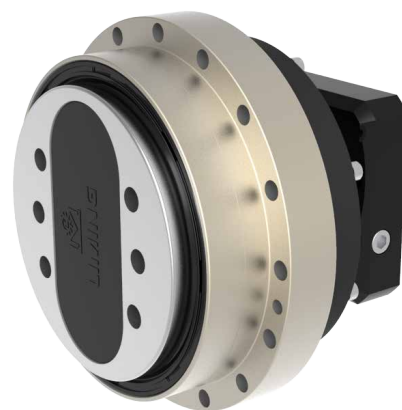

特性 Characteristic	代號	單位 Unit	RSN20
輸出平台支撐軸承 / Output Table Supporting Bearing			斜角滾珠軸承 Angular Contact Ball Bearing
額定輸出扭矩 / Rated Output Torque		Nm	200
最大輸出扭矩 / Max. Output Torque 急停扭矩 / Emergency Stop Torque	T_{2NOT}	Nm	5 倍額定輸出扭矩 5 Time of Rated Output Torque
最大加速力矩 / Max. Acceleration Torque	T_{2B}	Nm	2.5 倍額定輸出力矩 2.5 Times of Rated Output Torque
慣性慣量 / Inertia Moment		kg.m ²	2×10^{-4}
額定出力轉速 / Rated Output Speed		rpm	15
最大輸出轉速 / Max. Output Speed		rpm	50
容許輸入轉速 / Permissible Input Speed		rpm	3,000
背隙 / Backlash Ps	J_t	arcmin	≤ 1
背隙 / Backlash P0	J_t	arcmin	≤ 3
背隙 / Backlash P1	J_t	arcmin	≤ 5
容許徑向力 / Max. Radial Force	F_{2rB}	N	6,500
容許軸向力 / Max. Axial Force	F_{2aB}	N	4,300
額定壽命 / Rated Life	L_H	hr	S5 周期運轉 : >6,000 (S1 連續運轉 : >3,000 hrs) S5 Cycle Operation: >6,000 (S1 Continuous Operation: >3,000 hrs)
扭轉剛性 / Torsional Rigidity		Nm/arcmin	70
效率 / Efficiency	η	%	≥ 85
全合成潤滑油脂 / Synthetic Grease		g	170
重量 / Weight		kg	5.65

MODEL : RSN40

RATIO : 41、61、81、121、161

Unit: mm

Model Code	RSN40
A1	90、100、115、145
A2	M5、M6、M8
A3	70、80、95、110
A4	92、110、130
A5	19、24
A6	49、59

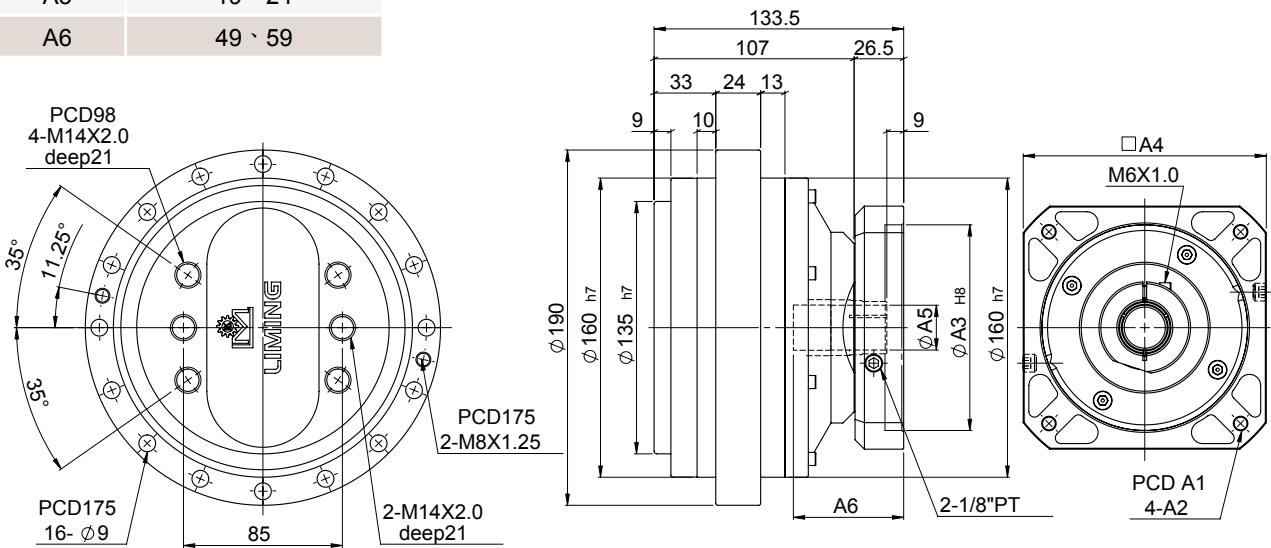
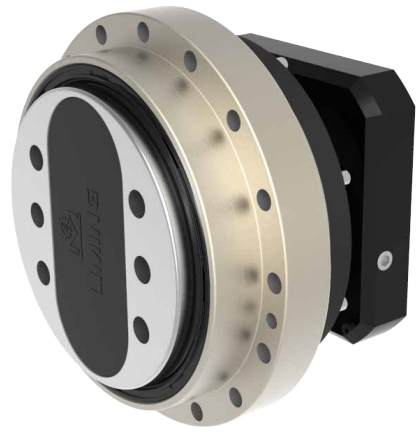

特性 Characteristic	代號	單位 Unit	RSN40
輸出平台支撐軸承 / Output Table Supporting Bearing			斜角滾珠軸承 Angular Contact Ball Bearing
額定輸出扭矩 / Rated Output Torque		Nm	400
最大輸出扭矩 / Max. Output Torque 急停扭矩 / Emergency Stop Torque	T_{2NOT}	Nm	5 倍額定輸出扭矩 5 Time of Rated Output Torque
最大加速力矩 / Max. Acceleration Torque	T_{2B}	Nm	2.5 倍額定輸出力矩 2.5 Times of Rated Output Torque
慣性慣量 / Inertia Moment		kg.m ²	5×10^{-4}
額定出力轉速 / Rated Output Speed		rpm	15
最大輸出轉速 / Max. Output Speed		rpm	45
容許輸入轉速 / Permissible Input Speed		rpm	3,000
背隙 / Backlash Ps	J_t	arcmin	≤ 1
背隙 / Backlash P0	J_t	arcmin	≤ 3
背隙 / Backlash P1	J_t	arcmin	≤ 5
容許徑向力 / Max. Radial Force	F_{2rB}	N	8,600
容許軸向力 / Max. Axial Force	F_{2aB}	N	5,700
額定壽命 / Rated Life	L_H	hr	S5 周期運轉 : >6,000 (S1 連續運轉 : >3,000 hrs) S5 Cycle Operation: >6,000 (S1 Continuous Operation: >3,000 hrs)
扭轉剛性 / Torsional Rigidity		Nm/arcmin	100
效率 / Efficiency	η	%	≥ 85
全合成潤滑油脂 / Synthetic Grease		g	290
重量 / Weight		kg	10.83

MODEL : RSN80

RATIO : 45、66、81、101、171

Unit: mm

Model Code	RSN80
A1	115、145、165
A2	M6、M8、M10
A3	95、110、130
A4	122、130、150
A5	24、28
A6	27.3、31.3

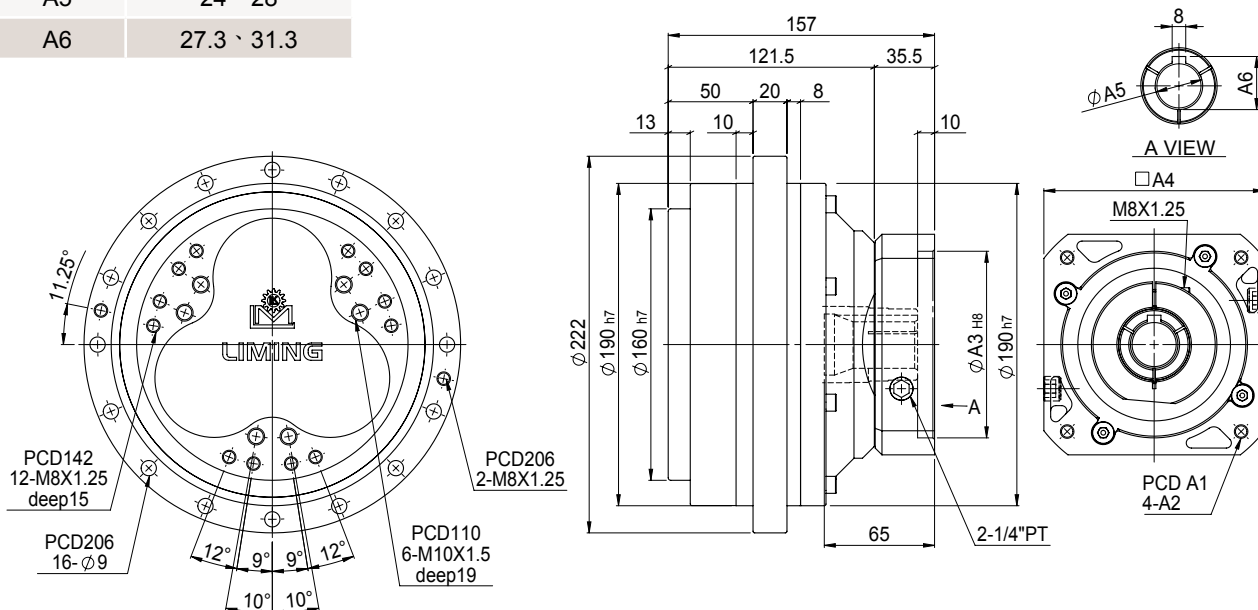

特性 Characteristic	代號	單位 Unit	RSN80
輸出平台支撐軸承 / Output Table Supporting Bearing			斜角滾珠軸承 Angular Contact Ball Bearing
額定輸出扭矩 / Rated Output Torque		Nm	800
最大輸出扭矩 / Max. Output Torque 急停扭矩 / Emergency Stop Torque	T_{2NOT}	Nm	5 倍額定輸出扭矩 5 Time of Rated Output Torque
最大加速力矩 / Max. Acceleration Torque	T_{2B}	Nm	2.5 倍額定輸出力矩 2.5 Times of Rated Output Torque
慣性慣量 / Inertia Moment		kg.m ²	9×10^{-4}
額定出力轉速 / Rated Output Speed		rpm	15
最大輸出轉速 / Max. Output Speed		rpm	42
容許輸入轉速 / Permissible Input Speed		rpm	3,000
背隙 / Backlash Ps	J_i	arcmin	≤ 1
背隙 / Backlash P0	J_i	arcmin	≤ 3
背隙 / Backlash P1	J_i	arcmin	≤ 5
容許徑向力 / Max. Radial Force	F_{2rB}	N	12,500
容許軸向力 / Max. Axial Force	F_{2aB}	N	8,200
額定壽命 / Rated Life	L_H	hr	S5 周期運轉 : >6,000 (S1 連續運轉 : >3,000 hrs) S5 Cycle Operation: >6,000 (S1 Continuous Operation: >3,000 hrs)
扭轉剛性 / Torsional Rigidity		Nm/arcmin	150
效率 / Efficiency	η	%	≥ 85
全合成潤滑油脂 / Synthetic Grease		g	480
重量 / Weight		kg	17.06

MODEL : RSN110

RATIO : 41、61、81、121、161

Unit: mm

Model Code	RSN110
A1	115、145、165
A2	M6、M8、M10
A3	95、110、130
A4	122、130、150
A5	28、32
A6	8、10
A7	31.3、35.3
A8	70、90

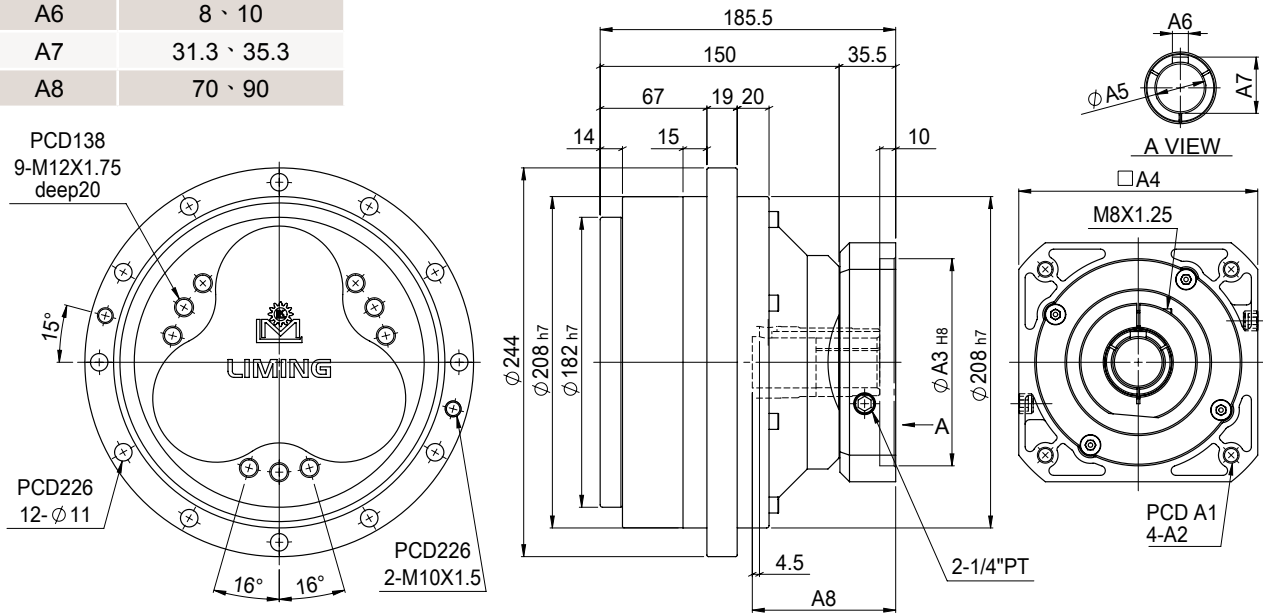
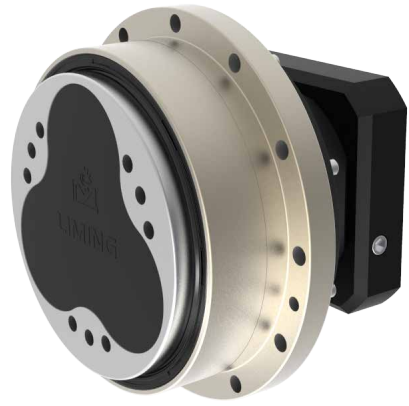

特性 Characteristic	代號	單位 Unit	RSN110
輸出平台支撐軸承 / Output Table Supporting Bearing			斜角滾珠軸承 Angular Contact Ball Bearing
額定輸出扭矩 / Rated Output Torque		Nm	1,100
最大輸出扭矩 / Max. Output Torque 急停扭矩 / Emergency Stop Torque	T_{2NOT}	Nm	5 倍額定輸出扭矩 5 Time of Rated Output Torque
最大加速力矩 / Max. Acceleration Torque	T_{2B}	Nm	2.5 倍額定輸出力矩 2.5 Times of Rated Output Torque
慣性慣量 / Inertia Moment		kg.m ²	15 x 10 ⁻⁴
額定出力轉速 / Rated Output Speed		rpm	15
最大輸出轉速 / Max. Output Speed		rpm	35
容許輸入轉速 / Permissible Input Speed		rpm	3,000
背隙 / Backlash Ps	J_i	arcmin	≤ 1
背隙 / Backlash P0	J_i	arcmin	≤ 3
背隙 / Backlash P1	J_i	arcmin	≤ 5
容許徑向力 / Max. Radial Force	F_{2rB}	N	16,000
容許軸向力 / Max. Axial Force	F_{2aB}	N	12,000
額定壽命 / Rated Life	L_H	hr	S5 周期運轉 : >6,000 (S1 連續運轉 : >3,000 hrs) S5 Cycle Operation: >6,000 (S1 Continuous Operation: >3,000 hrs)
扭轉剛性 / Torsional Rigidity		Nm/arcmin	210
效率 / Efficiency	η	%	≥ 85
全合成潤滑油脂 / Synthetic Grease		g	710
重量 / Weight		kg	22.45

MODEL : RSN160

RATIO : 41、61、81、121、161

Unit: mm

Model Code	RSN160
A1	145、165、200
A2	M8、M10、M12
A3	110、130、180
A4	146、150、190
A5	32、35
A6	35.3、38.3

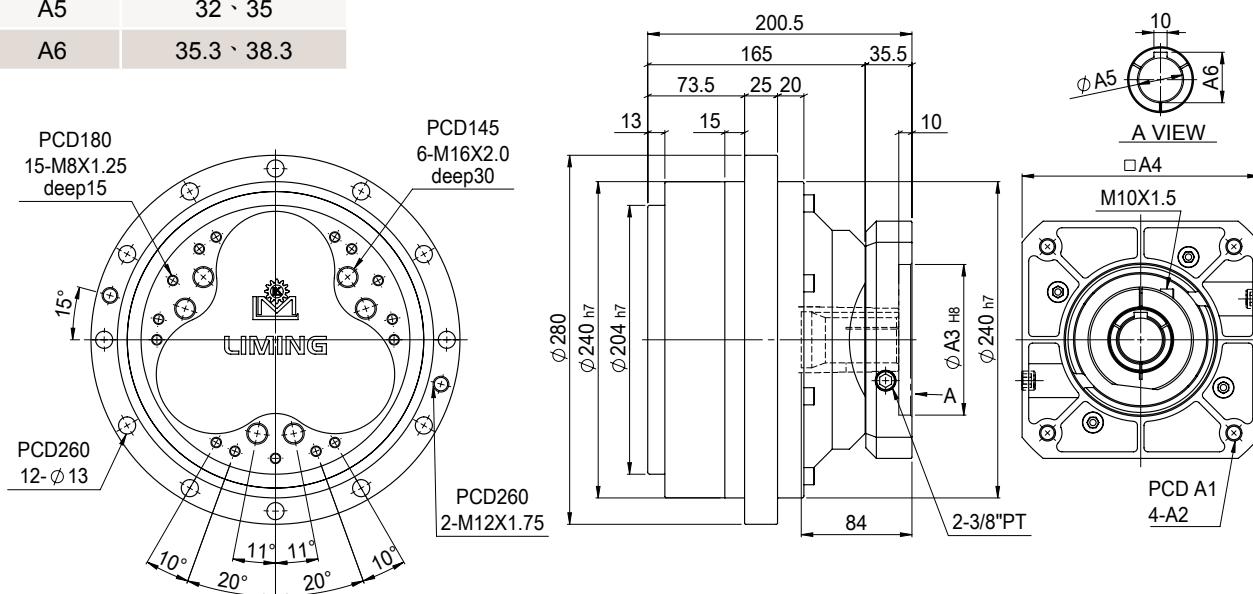

特性 Characteristic	代號	單位 Unit	RSN160
輸出平台支撐軸承 / Output Table Supporting Bearing			斜角滾珠軸承 Angular Contact Ball Bearing
額定輸出扭矩 / Rated Output Torque		Nm	1,600
最大輸出扭矩 / Max. Output Torque 急停扭矩 / Emergency Stop Torque	T_{2NOT}	Nm	5 倍額定輸出扭矩 5 Time of Rated Output Torque
最大加速力矩 / Max. Acceleration Torque	T_{2B}	Nm	2.5 倍額定輸出力矩 2.5 Times of Rated Output Torque
慣性慣量 / Inertia Moment		kg.m ²	25 x 10 ⁻⁴
額定出力轉速 / Rated Output Speed		rpm	15
最大輸出轉速 / Max. Output Speed		rpm	27
容許輸入轉速 / Permissible Input Speed		rpm	3,000
背隙 / Backlash Ps	J_i	arcmin	≤ 1
背隙 / Backlash P0	J_i	arcmin	≤ 3
背隙 / Backlash P1	J_i	arcmin	≤ 5
容許徑向力 / Max. Radial Force	F_{2rB}	N	19,000
容許軸向力 / Max. Axial Force	F_{2aB}	N	15,000
額定壽命 / Rated Life	L_H	hr	S5 周期運轉 : >6,000 (S1 連續運轉 : >3,000 hrs) S5 Cycle Operation: >6,000 (S1 Continuous Operation: >3,000 hrs)
扭轉剛性 / Torsional Rigidity		Nm/arcmin	300
效率 / Efficiency	η	%	≥ 85
全合成潤滑油脂 / Synthetic Grease		g	800
重量 / Weight		kg	35.25

MODEL : RSN320

RATIO : 41、61、81、121、161

Unit: mm

Model Code	RSN320
A1	165、200、215
A2	M8、M10、M12
A3	114.3、130、180
A4	182、200
A5	35、38
A6	38.3、41.3

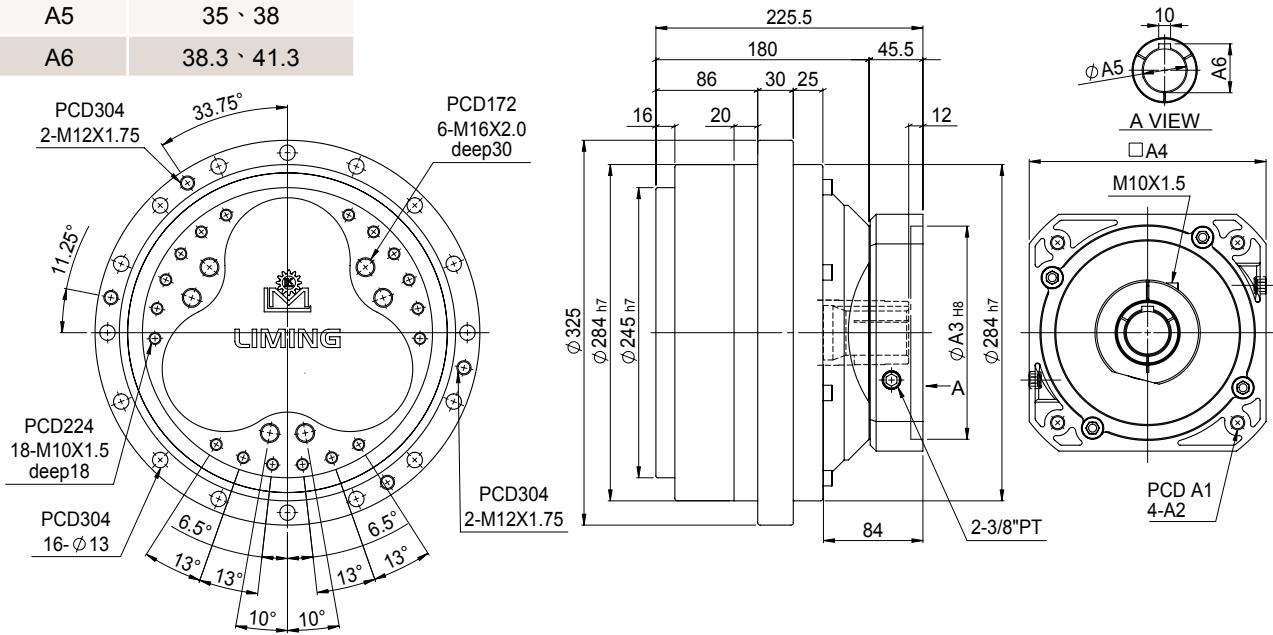

特性 Characteristic	代號	單位 Unit	RSN320
輸出平台支撐軸承 / Output Table Supporting Bearing			斜角滾珠軸承 Angular Contact Ball Bearing
額定輸出扭矩 / Rated Output Torque		Nm	3,200
最大輸出扭矩 / Max. Output Torque 急停扭矩 / Emergency Stop Torque	T_{2NOT}	Nm	5 倍額定輸出扭矩 5 Time of Rated Output Torque
最大加速力矩 / Max. Acceleration Torque	T_{2B}	Nm	2.5 倍額定輸出力矩 2.5 Times of Rated Output Torque
慣性慣量 / Inertia Moment		kg.m ²	32 x 10 ⁻⁴
額定出力轉速 / Rated Output Speed		rpm	15
最大輸出轉速 / Max. Output Speed		rpm	21
容許輸入轉速 / Permissible Input Speed		rpm	3,000
背隙 / Backlash Ps	J_i	arcmin	≤ 1
背隙 / Backlash P0	J_i	arcmin	≤ 3
背隙 / Backlash P1	J_i	arcmin	≤ 5
容許徑向力 / Max. Radial Force	F_{2rB}	N	25,300
容許軸向力 / Max. Axial Force	F_{2aB}	N	20,000
額定壽命 / Rated Life	L_H	hr	S5 周期運轉 : >6,000 (S1 連續運轉 : >3,000 hrs) S5 Cycle Operation: >6,000 (S1 Continuous Operation: >3,000 hrs)
扭轉剛性 / Torsional Rigidity		Nm/arcmin	980
效率 / Efficiency	η	%	≥ 85
全合成潤滑油脂 / Synthetic Grease		g	1,700
重量 / Weight		kg	55.9



RDN

高精密擺線減速機

MODEL : RDN6

RATIO : 41、61、81、121、161

Unit: mm

Model Code	RDN6
A1	70、75、90
A2	M4、M5、M6
A3	50、60、70
A4	64、70、80

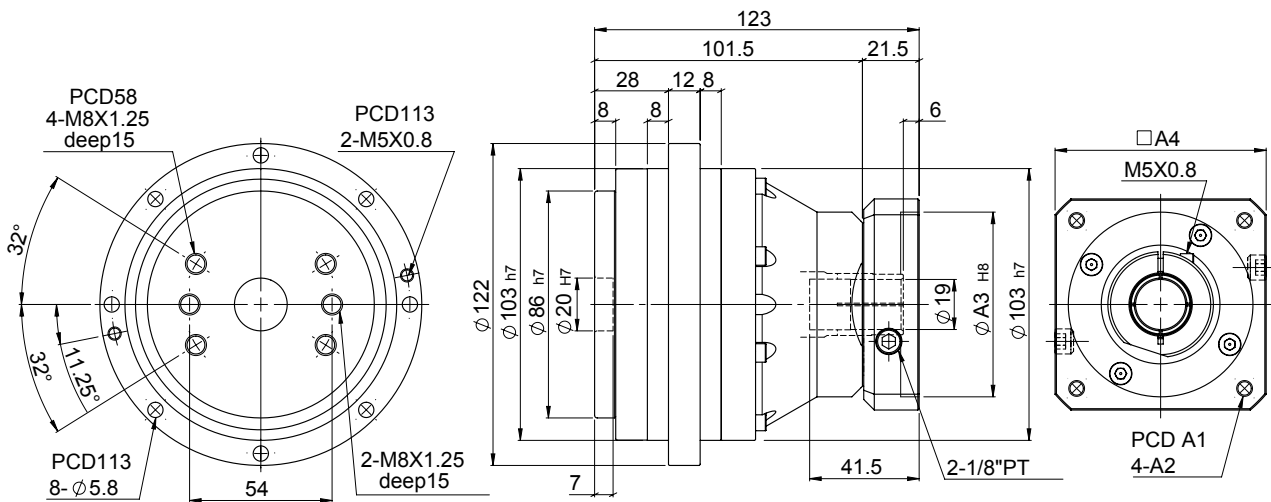

特性 Characteristic	代號	單位 Unit	RDN6
輸出平台支撐軸承 / Output Table Supporting Bearing			斜角滾珠軸承 Angular Contact Ball Bearing
額定輸出扭矩 / Rated Output Torque		Nm	60
最大輸出扭矩 / Max. Output Torque 急停扭矩 / Emergency Stop Torque	T_{2NOT}	Nm	5 倍額定輸出扭矩 5 Time of Rated Output Torque
最大加速力矩 / Max. Acceleration Torque	T_{2B}	Nm	2 倍額定輸出力矩 2Times of Rated Ouput Torque
慣性慣量 / Inertia Moment		kg.m ²	1.15 x 10 ⁻⁴
額定出力轉速 / Rated Output Speed		rpm	15
最大輸出轉速 / Max. Output Speed		rpm	55
容許輸入轉速 / Permissible Input Speed		rpm	3,000
背隙 / Backlash Ps	J_i	arcmin	≤ 2
背隙 / Backlash P0	J_i	arcmin	≤ 4
背隙 / Backlash P1	J_i	arcmin	≤ 6
容許徑向力 / Max. Radial Force	F_{2rB}	N	2,100
容許軸向力 / Max. Axial Force	F_{2aB}	N	1,500
額定壽命 / Rated Life	L_H	hr	S5 周期運轉 : >6,000 (S1 連續運轉 : >3,000 hrs) S5 Cycle Operation: >6,000 (S1 Continuous Operation: >3,000 hrs)
扭轉剛性 / Torsional Rigidity		Nm/arcmin	50
效率 / Efficiency	η	%	≥ 85
全合成潤滑油脂 / Synthetic Grease		g	100
重量 / Weight		kg	3.43

MODEL : RDN20

RATIO : 41、61、81、121、161

Unit: mm

Model Code	RDN20
A1	90、100、115、145
A2	M5、M6、M8
A3	70、80、95、110
A4	92、110、130
A5	19、24
A6	51、63
A7	8、20
A8	26.5、38.5
A9	146、158

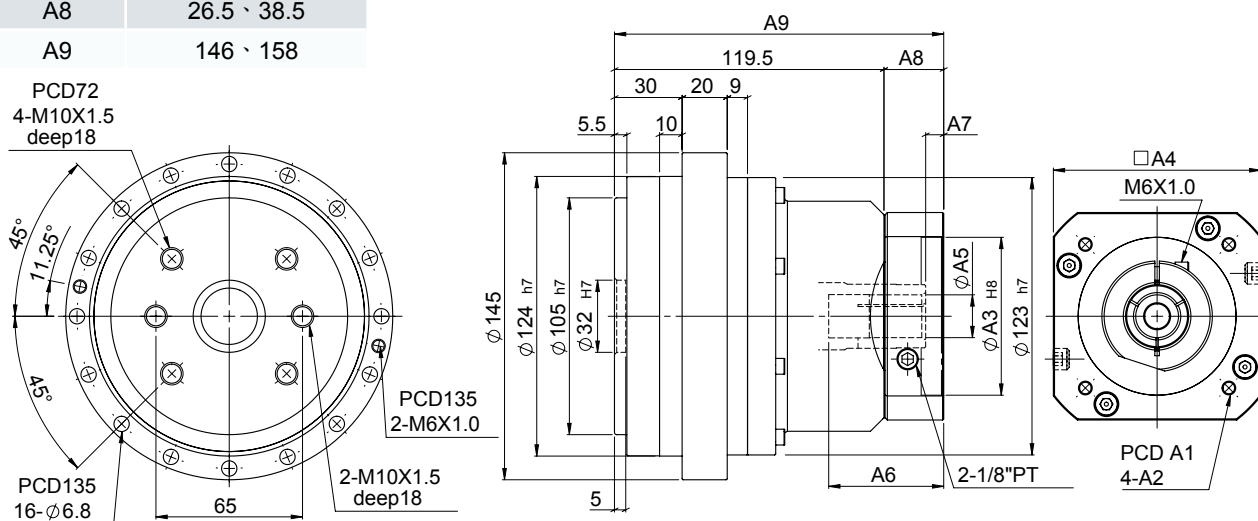

特性 Characteristic	代號	單位 Unit	RDN20
輸出平台支撐軸承 / Output Table Supporting Bearing			斜角滾珠軸承 Angular Contact Ball Bearing
額定輸出扭矩 / Rated Output Torque		Nm	200
最大輸出扭矩 / Max. Output Torque 急停扭矩 / Emergency Stop Torque	T_{2NOT}	Nm	5 倍額定輸出扭矩 5 Time of Rated Output Torque
最大加速力矩 / Max. Acceleration Torque	T_{2B}	Nm	2.5 倍額定輸出力矩 2.5 Times of Rated Output Torque
慣性慣量 / Inertia Moment		kg.m ²	2 x 10 ⁻⁴
額定出力轉速 / Rated Output Speed		rpm	15
最大輸出轉速 / Max. Output Speed		rpm	50
容許輸入轉速 / Permissible Input Speed		rpm	3,000
背隙 / Backlash Ps	J_i	arcmin	≤ 1
背隙 / Backlash P0	J_i	arcmin	≤ 3
背隙 / Backlash P1	J_i	arcmin	≤ 5
容許徑向力 / Max. Radial Force	F_{2rB}	N	6,500
容許軸向力 / Max. Axial Force	F_{2aB}	N	4,300
額定壽命 / Rated Life	L_H	hr	S5 周期運轉 : >6,000 (S1 連續運轉 : >3,000 hrs) S5 Cycle Operation: >6,000 (S1 Continuous Operation: >3,000 hrs)
扭轉剛性 / Torsional Rigidity		Nm/arcmin	70
效率 / Efficiency	η	%	≥ 85
全合成潤滑油脂 / Synthetic Grease		g	170
重量 / Weight		kg	6.43

MODEL : RDN40

RATIO : 41、61、81、121、161

Unit: mm

Model Code	RDN40
A1	115、145、165
A2	M6、M8、M10
A3	95、110、130
A4	122、130、150
A5	24、28

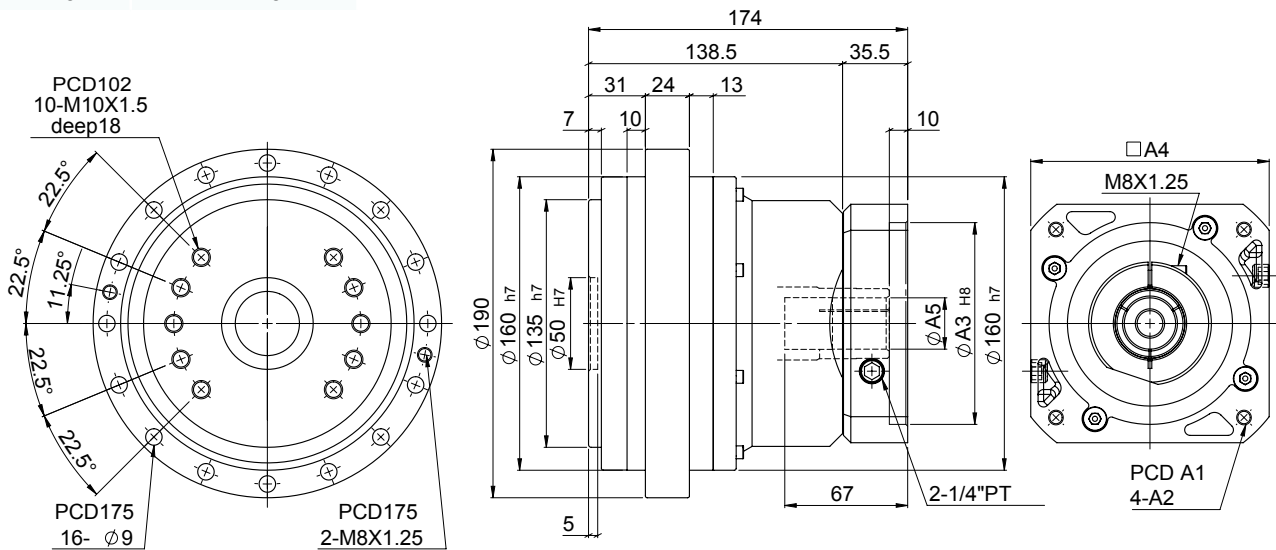

特性 Characteristic	代號	單位 Unit	RDN40
輸出平台支撐軸承 / Output Table Supporting Bearing			斜角滾珠軸承 Angular Contact Ball Bearing
額定輸出扭矩 / Rated Output Torque		Nm	400
最大輸出扭矩 / Max. Output Torque 急停扭矩 / Emergency Stop Torque	T_{2NOT}	Nm	5 倍額定輸出扭矩 5 Time of Rated Output Torque
最大加速力矩 / Max. Acceleration Torque	T_{2B}	Nm	2.5 倍額定輸出力矩 2.5 Times of Rated Output Torque
慣性慣量 / Inertia Moment		kg.m ²	5 x 10 ⁻⁴
額定出力轉速 / Rated Output Speed		rpm	15
最大輸出轉速 / Max. Output Speed		rpm	45
容許輸入轉速 / Permissible Input Speed		rpm	3,000
背隙 / Backlash Ps	J_i	arcmin	≤ 1
背隙 / Backlash P0	J_i	arcmin	≤ 3
背隙 / Backlash P1	J_i	arcmin	≤ 5
容許徑向力 / Max. Radial Force	F_{2rB}	N	8,600
容許軸向力 / Max. Axial Force	F_{2aB}	N	5,700
額定壽命 / Rated Life	L_H	hr	S5 周期運轉 : >6,000 (S1 連續運轉 : >3,000 hrs) S5 Cycle Operation: >6,000 (S1 Continuous Operation: >3,000 hrs)
扭轉剛性 / Torsional Rigidity		Nm/arcmin	100
效率 / Efficiency	η	%	≥ 85
全合成潤滑油脂 / Synthetic Grease		g	290
重量 / Weight		kg	11.3

MODEL : RDN80

RATIO : 45、66、81、101、171

Unit: mm

Model Code	RDN80
A1	115、145、165
A2	M6、M8、M10
A3	95、110、130
A4	122、130、150
A5	28、32

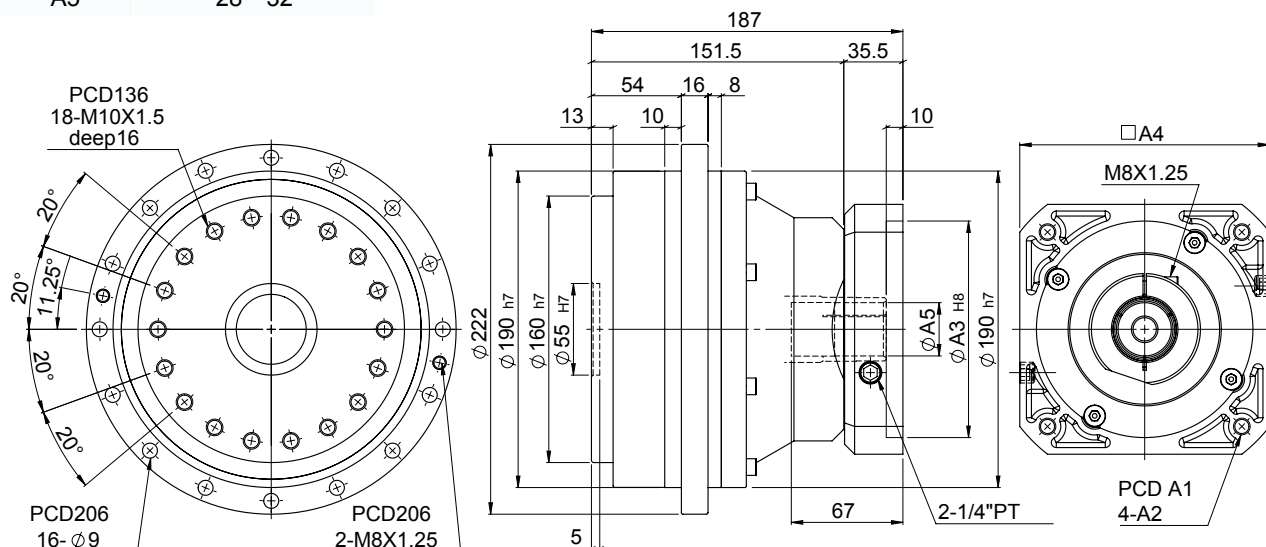
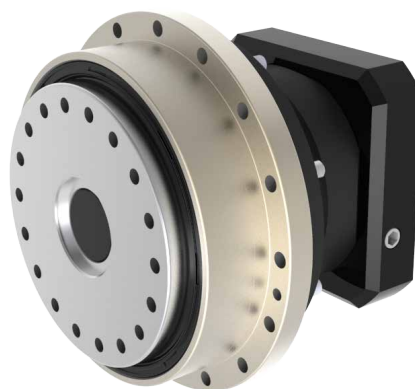

特性 Characteristic	代號	單位 Unit	RDN80
輸出平台支撐軸承 / Output Table Supporting Bearing			斜角滾珠軸承 Angular Contact Ball Bearing
額定輸出扭矩 / Rated Output Torque		Nm	800
最大輸出扭矩 / Max. Output Torque 急停扭矩 / Emergency Stop Torque	T_{2NOT}	Nm	5 倍額定輸出扭矩 5 Time of Rated Output Torque
最大加速力矩 / Max. Acceleration Torque	T_{2B}	Nm	2.5 倍額定輸出力矩 2.5 Times of Rated Output Torque
慣性慣量 / Inertia Moment		kg.m ²	9 x 10 ⁻⁴
額定出力轉速 / Rated Output Speed		rpm	15
最大輸出轉速 / Max. Output Speed		rpm	42
容許輸入轉速 / Permissible Input Speed		rpm	3,000
背隙 / Backlash Ps	J_i	arcmin	≤ 1
背隙 / Backlash P0	J_i	arcmin	≤ 3
背隙 / Backlash P1	J_i	arcmin	≤ 5
容許徑向力 / Max. Radial Force	F_{2rB}	N	12,500
容許軸向力 / Max. Axial Force	F_{2aB}	N	8,200
額定壽命 / Rated Life	L_H	hr	S5 周期運轉 : >6,000 (S1 連續運轉 : >3,000 hrs) S5 Cycle Operation: >6,000 (S1 Continuous Operation: >3,000 hrs)
扭轉剛性 / Torsional Rigidity		Nm/arcmin	150
效率 / Efficiency	η	%	≥ 85
全合成潤滑油脂 / Synthetic Grease		g	480
重量 / Weight		kg	18.64

MODEL : RDN110

RATIO : 41、61、81、121、161

Unit: mm

Model Code	RDN110
A1	145、165、200
A2	M8、M10、M12
A3	110、130、180
A4	146、150、190
A5	32、35
A6	35.3、38.3

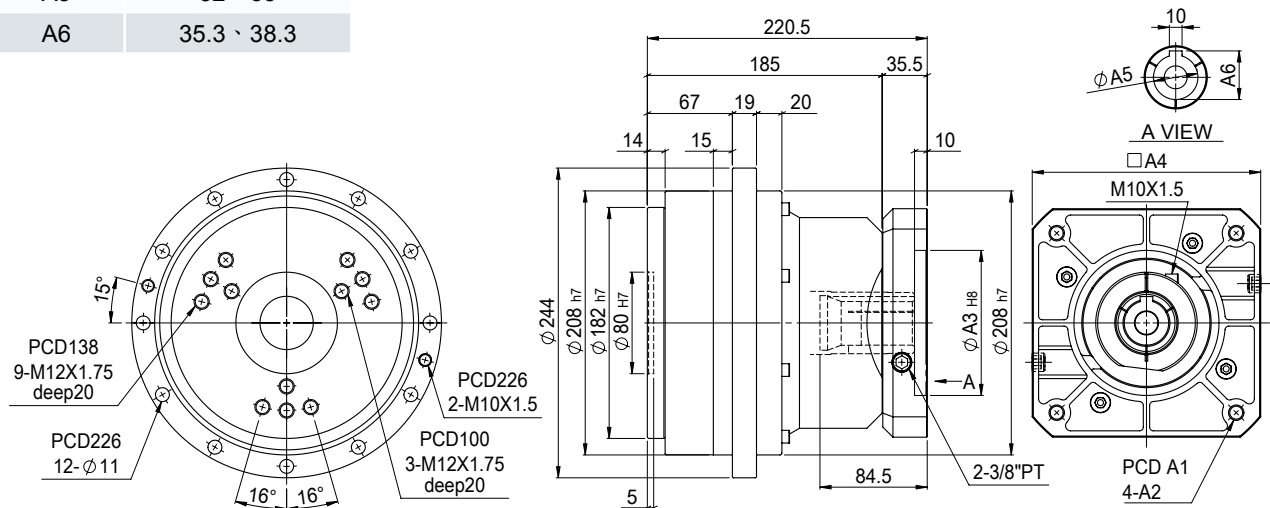

特性 Characteristic	代號	單位 Unit	RDN110
輸出平台支撐軸承 / Output Table Supporting Bearing			斜角滾珠軸承 Angular Contact Ball Bearing
額定輸出扭矩 / Rated Output Torque		Nm	1,100
最大輸出扭矩 / Max. Output Torque 急停扭矩 / Emergency Stop Torque	T_{2NOT}	Nm	5 倍額定輸出扭矩 5 Time of Rated Output Torque
最大加速力矩 / Max. Acceleration Torque	T_{2B}	Nm	2.5 倍額定輸出力矩 2.5 Times of Rated Output Torque
慣性慣量 / Inertia Moment		kg.m ²	15 x 10 ⁻⁴
額定出力轉速 / Rated Output Speed		rpm	15
最大輸出轉速 / Max. Output Speed		rpm	35
容許輸入轉速 / Permissible Input Speed		rpm	3,000
背隙 / Backlash Ps	J_i	arcmin	≤ 1
背隙 / Backlash P0	J_i	arcmin	≤ 3
背隙 / Backlash P1	J_i	arcmin	≤ 5
容許徑向力 / Max. Radial Force	F_{2rB}	N	16,000
容許軸向力 / Max. Axial Force	F_{2aB}	N	12,000
額定壽命 / Rated Life	L_H	hr	S5 周期運轉 : >6,000 (S1 連續運轉 : >3,000 hrs) S5 Cycle Operation: >6,000 (S1 Continuous Operation: >3,000 hrs)
扭轉剛性 / Torsional Rigidity		Nm/arcmin	210
效率 / Efficiency	η	%	≥ 85
全合成潤滑油脂 / Synthetic Grease		g	710
重量 / Weight		kg	26.8

MODEL : RDN160

RATIO : 41、61、81、121、161

Unit: mm

Model Code	RDN160
A1	165、200、215
A2	M8、M10、M12
A3	114.3、130、180
A4	182、200
A5	35、38
A6	38.3、41.3

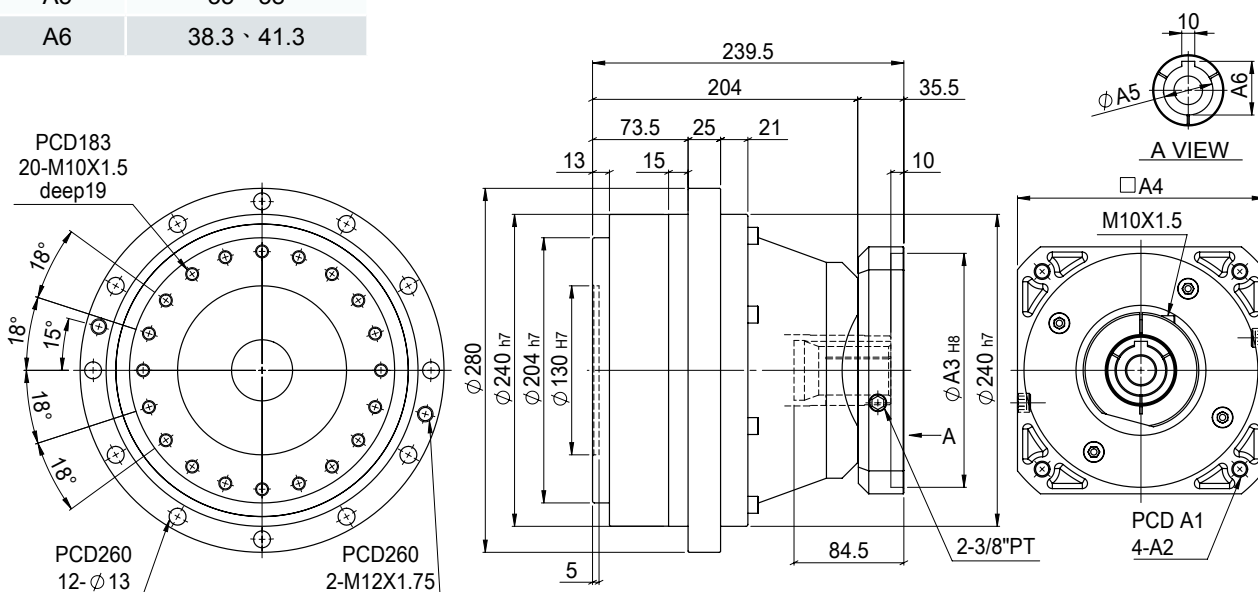
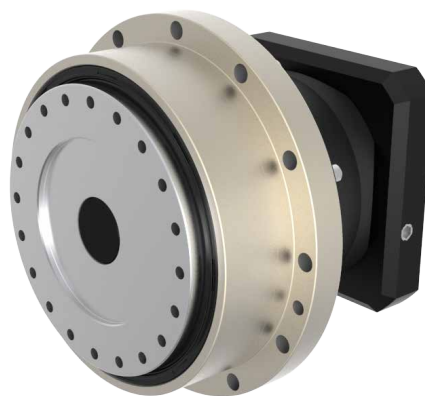

特性 Characteristic	代號	單位 Unit	RDN160
輸出平台支撐軸承 / Output Table Supporting Bearing			斜角滾珠軸承 Angular Contact Ball Bearing
額定輸出扭矩 / Rated Output Torque		Nm	1,600
最大輸出扭矩 / Max. Output Torque 急停扭矩 / Emergency Stop Torque	T_{2NOT}	Nm	5 倍額定輸出扭矩 5 Time of Rated Output Torque
最大加速力矩 / Max. Acceleration Torque	T_{2B}	Nm	2.5 倍額定輸出力矩 2.5 Times of Rated Output Torque
慣性慣量 / Inertia Moment		kg.m ²	25 x 10 ⁻⁴
額定出力轉速 / Rated Output Speed		rpm	15
最大輸出轉速 / Max. Output Speed		rpm	27
容許輸入轉速 / Permissible Input Speed		rpm	3,000
背隙 / Backlash Ps	J_i	arcmin	≤ 1
背隙 / Backlash P0	J_i	arcmin	≤ 3
背隙 / Backlash P1	J_i	arcmin	≤ 5
容許徑向力 / Max. Radial Force	F_{2rB}	N	19,000
容許軸向力 / Max. Axial Force	F_{2aB}	N	15,000
額定壽命 / Rated Life	L_H	hr	S5 周期運轉 : >6,000 (S1 連續運轉 : >3,000 hrs) S5 Cycle Operation: >6,000 (S1 Continuous Operation: >3,000 hrs)
扭轉剛性 / Torsional Rigidity		Nm/arcmin	300
效率 / Efficiency	η	%	≥ 85
全合成潤滑油脂 / Synthetic Grease		g	800
重量 / Weight		kg	36.4

MODEL : RDN320

RATIO : 41、61、81、121、161

Unit: mm

Model Code	RDN320
A1	200、215、265
A2	M10、M12、M16
A3	114.3、180、230
A4	182、200、250
A5	42、48
A6	12、14
A7	45.3、51.8

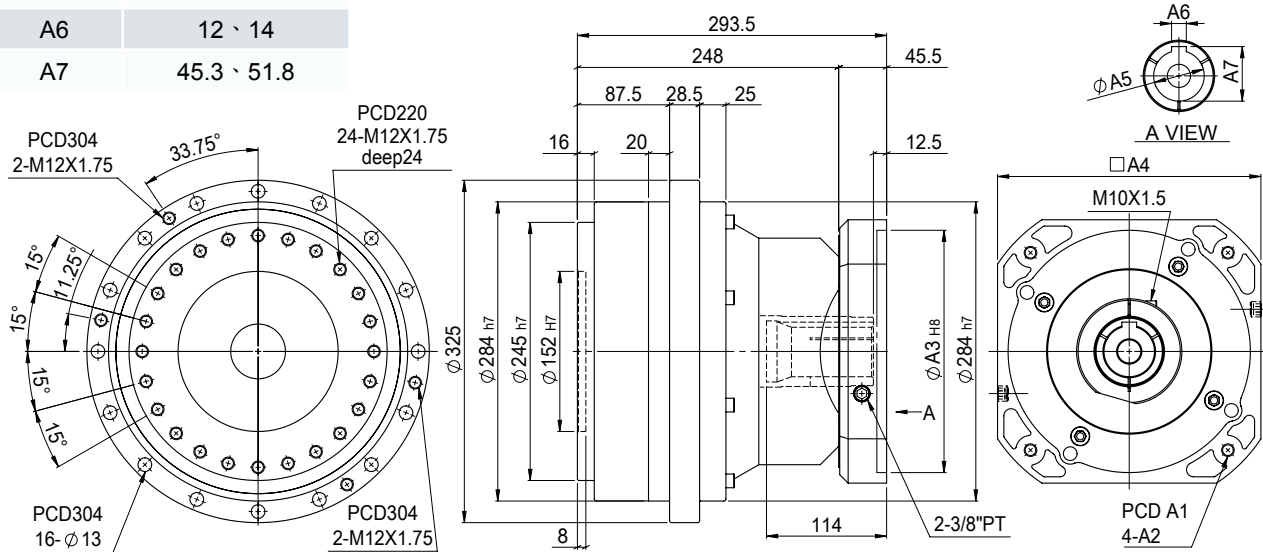

特性 Characteristic	代號	單位 Unit	RDN320
輸出平台支撐軸承 / Output Table Supporting Bearing			斜角滾珠軸承 Angular Contact Ball Bearing
額定輸出扭矩 / Rated Output Torque		Nm	3,200
最大輸出扭矩 / Max. Output Torque 急停扭矩 / Emergency Stop Torque	T_{2NOT}	Nm	5 倍額定輸出扭矩 5 Time of Rated Output Torque
最大加速力矩 / Max. Acceleration Torque	T_{2B}	Nm	2.5 倍額定輸出力矩 2.5 Times of Rated Output Torque
慣性慣量 / Inertia Moment		kg.m ²	32 x 10 ⁻⁴
額定出力轉速 / Rated Output Speed		rpm	15
最大輸出轉速 / Max. Output Speed		rpm	21
容許輸入轉速 / Permissible Input Speed		rpm	3,000
背隙 / Backlash Ps	J_i	arcmin	≤ 1
背隙 / Backlash P0	J_i	arcmin	≤ 3
背隙 / Backlash P1	J_i	arcmin	≤ 5
容許徑向力 / Max. Radial Force	F_{2rB}	N	25,300
容許軸向力 / Max. Axial Force	F_{2aB}	N	20,000
額定壽命 / Rated Life	L_H	hr	S5 周期運轉 : >6,000 (S1 連續運轉 : >3,000 hrs) S5 Cycle Operation: >6,000 (S1 Continuous Operation: >3,000 hrs)
扭轉剛性 / Torsional Rigidity		Nm/arcmin	980
效率 / Efficiency	η	%	≥ 85
全合成潤滑油脂 / Synthetic Grease		g	1,700
重量 / Weight		kg	62.7



RCN

高精度擺線減速機

MODEL : RCN6

RATIO : 75、100、125、150

Unit: mm

Model Code	RCN6
A1	70、75、90
A2	M4、M5、M6
A3	50、60、70
A4	64、70、80

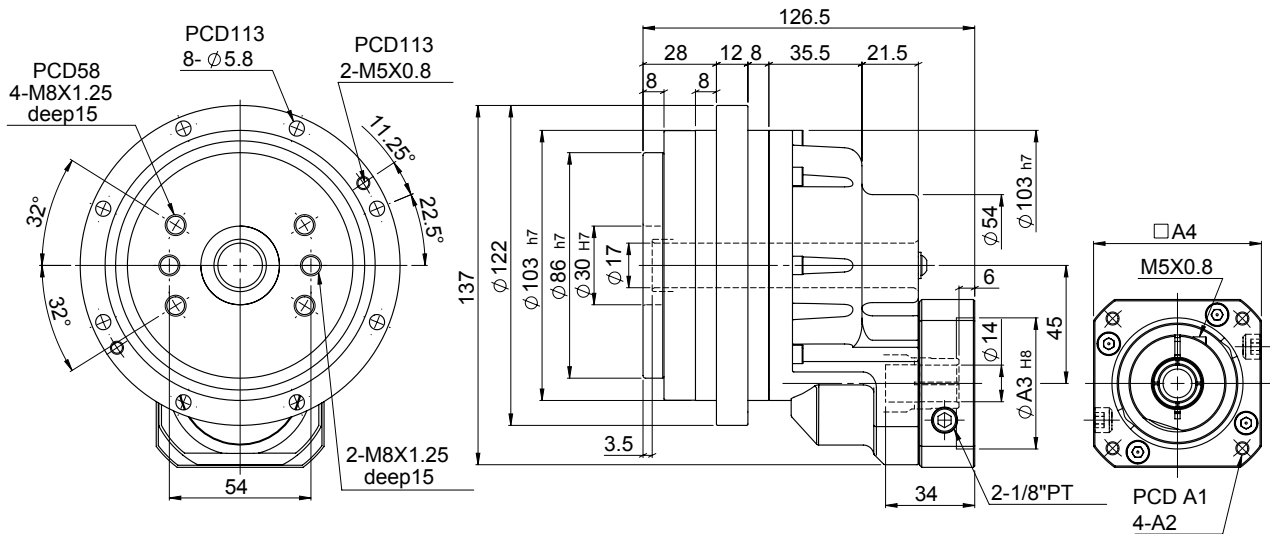

特性 Characteristic	代號	單位 Unit	RCN6
輸出平台支撐軸承 / Output Table Supporting Bearing			斜角滾珠軸承 Angular Contact Ball Bearing
額定輸出扭矩 / Rated Output Torque		Nm	60
最大輸出扭矩 / Max. Output Torque	T_{2NOT}	Nm	5 倍額定輸出扭矩 5 Time of Rated Output Torque
急停扭矩 / Emergency Stop Torque			
最大加速力矩 / Max. Acceleration Torque	T_{2B}	Nm	2 倍額定輸出力矩 2 Times of Rated Output Torque
慣性慣量 / Inertia Moment		kg.m ²	1.15 x 10 ⁻⁴
額定出力轉速 / Rated Output Speed		rpm	15
最大輸出轉速 / Max. Output Speed		rpm	55
容許輸入轉速 / Permissible Input Speed		rpm	3,000
背隙 / Backlash Ps	J_t	arcmin	≤ 2
背隙 / Backlash P0	J_t	arcmin	≤ 4
背隙 / Backlash P1	J_t	arcmin	≤ 6
容許徑向力 / Max. Radial Force	F_{2rB}	N	2,100
容許軸向力 / Max. Axial Force	F_{2aB}	N	1,500
額定壽命 / Rated Life	L_H	hr	S5 周期運轉 : >6,000 (S1 連續運轉 : >3,000 hrs) S5 Cycle Operation: >6,000 (S1 Continuous Operation: >3,000 hrs)
扭轉剛性 / Torsional Rigidity		Nm/arcmin	50
效率 / Efficiency	η	%	≥ 85
全合成潤滑油脂 / Synthetic Grease		g	100
重量 / Weight		kg	3.6

MODEL : RCN20

RATIO : 69、115、138

Unit: mm

Model Code	RCN20
A1	70、75、90
A2	M4、M5、M6
A3	50、60、70
A4	64、70、80
A5	※ 14、19
A6	33.5、41.5

※ Ø14 : 1/69、1/115、1/138
 ※ Ø19 : 1/69、1/115

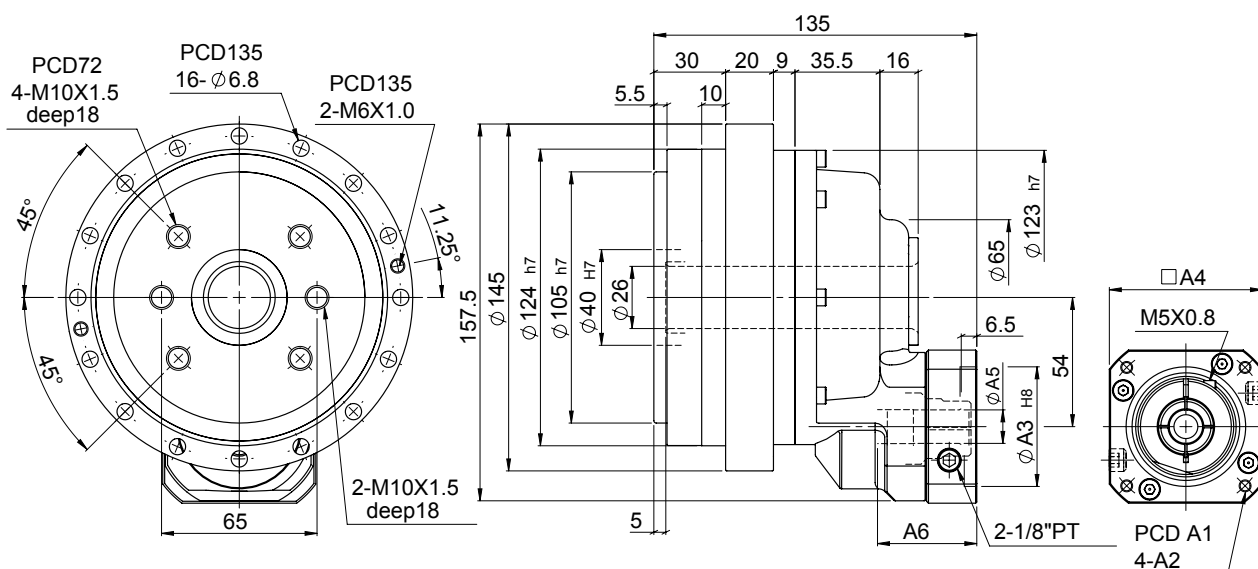

特性 Characteristic	代號	單位 Unit	RCN20
輸出平台支撐軸承 / Output Table Supporting Bearing			斜角滾珠軸承 Angular Contact Ball Bearing
額定輸出扭矩 / Rated Output Torque		Nm	200
最大輸出扭矩 / Max. Output Torque 急停扭矩 / Emergency Stop Torque	T_{2NOT}	Nm	5 倍額定輸出扭矩 5 Time of Rated Output Torque
最大加速力矩 / Max. Acceleration Torque	T_{2B}	Nm	2.5 倍額定輸出力矩 2.5 Times of Rated Output Torque
慣性慣量 / Inertia Moment		kg.m ²	2×10^{-4}
額定出力轉速 / Rated Output Speed		rpm	15
最大輸出轉速 / Max. Output Speed		rpm	50
容許輸入轉速 / Permissible Input Speed		rpm	3,000
背隙 / Backlash Ps	J_t	arcmin	≤ 1
背隙 / Backlash P0	J_t	arcmin	≤ 3
背隙 / Backlash P1	J_t	arcmin	≤ 5
容許徑向力 / Max. Radial Force	F_{2rB}	N	6,500
容許軸向力 / Max. Axial Force	F_{2aB}	N	4,300
額定壽命 / Rated Life	L_H	hr	S5 周期運轉 : >6,000 (S1 連續運轉 : >3,000 hrs) S5 Cycle Operation: >6,000 (S1 Continuous Operation: >3,000 hrs)
扭轉剛性 / Torsional Rigidity		Nm/arcmin	70
效率 / Efficiency	η	%	≥ 85
全合成潤滑油脂 / Synthetic Grease		g	170
重量 / Weight		kg	6.45

MODEL : RCN40

RATIO : 87、116、145

Unit: mm

Model Code	RCN40
A1	90、100、115、145
A2	M5、M6、M8
A3	70、80、95、110
A4	92、110、130
A5	※19、22
A6	44、58

※ Ø19 : 1/87、1/116、1/145
 ※ Ø22 : 1/87、1/116

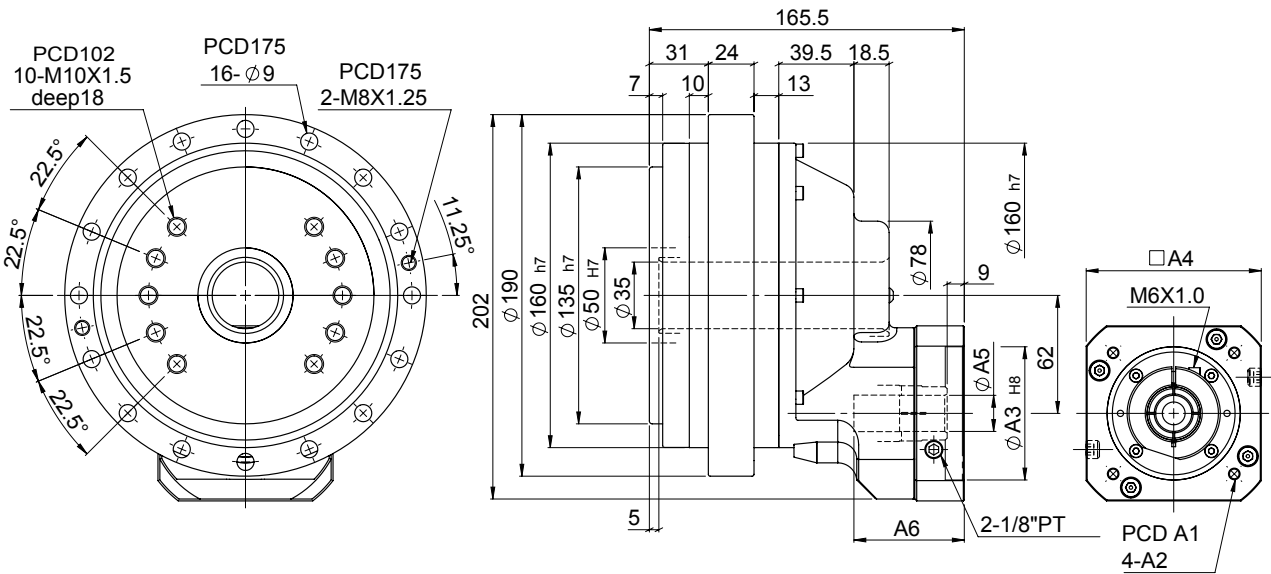

特性 Characteristic	代號	單位 Unit	RCN40
輸出平台支撐軸承 / Output Table Supporting Bearing			斜角滾珠軸承 Angular Contact Ball Bearing
額定輸出扭矩 / Rated Output Torque		Nm	400
最大輸出扭矩 / Max. Output Torque 急停扭矩 / Emergency Stop Torque	T_{2NOT}	Nm	5 倍額定輸出扭矩 5 Time of Rated Output Torque
最大加速力矩 / Max. Acceleration Torque	T_{2B}	Nm	2.5 倍額定輸出力矩 2.5 Times of Rated Output Torque
慣性慣量 / Inertia Moment		kg.m ²	5 x 10 ⁻⁴
額定出力轉速 / Rated Output Speed		rpm	15
最大輸出轉速 / Max. Output Speed		rpm	45
容許輸入轉速 / Permissible Input Speed		rpm	3,000
背隙 / Backlash Ps	J_i	arcmin	≤ 1
背隙 / Backlash P0	J_i	arcmin	≤ 3
背隙 / Backlash P1	J_i	arcmin	≤ 5
容許徑向力 / Max. Radial Force	F_{2rB}	N	8,600
容許軸向力 / Max. Axial Force	F_{2aB}	N	5,700
額定壽命 / Rated Life	L_H	hr	S5 周期運轉 : >6,000 (S1 連續運轉 : >3,000 hrs) S5 Cycle Operation: >6,000 (S1 Continuous Operation: >3,000 hrs)
扭轉剛性 / Torsional Rigidity		Nm/arcmin	100
效率 / Efficiency	η	%	≥ 85
全合成潤滑油脂 / Synthetic Grease		g	290
重量 / Weight		kg	11.4

MODEL : RCN80

RATIO : 78、104、130

Unit: mm



Model Code	RCN80
A1	90、100、115、145
A2	M5、M6、M8
A3	70、80、95、110
A4	92、110、130
A5	22、24

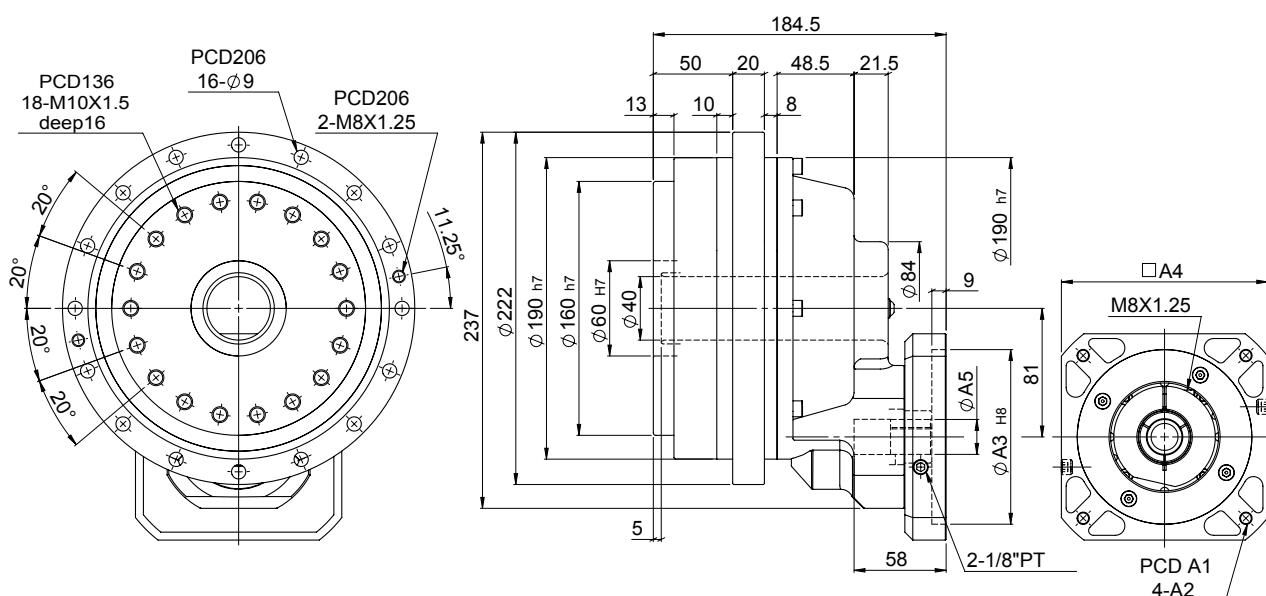

特性 Characteristic	代號	單位 Unit	RCN80
輸出平台支撐軸承 / Output Table Supporting Bearing			斜角滾珠軸承 Angular Contact Ball Bearing
額定輸出扭矩 / Rated Output Torque		Nm	800
最大輸出扭矩 / Max. Output Torque 急停扭矩 / Emergency Stop Torque	T_{2NOT}	Nm	5 倍額定輸出扭矩 5 Time of Rated Output Torque
最大加速力矩 / Max. Acceleration Torque	T_{2B}	Nm	2.5 倍額定輸出力矩 2.5 Times of Rated Output Torque
慣性慣量 / Inertia Moment		kg.m ²	9 x 10 ⁻⁴
額定出力轉速 / Rated Output Speed		rpm	15
最大輸出轉速 / Max. Output Speed		rpm	42
容許輸入轉速 / Permissible Input Speed		rpm	3,000
背隙 / Backlash Ps	J_i	arcmin	≤ 1
背隙 / Backlash P0	J_i	arcmin	≤ 3
背隙 / Backlash P1	J_i	arcmin	≤ 5
容許徑向力 / Max. Radial Force	F_{2rB}	N	12,500
容許軸向力 / Max. Axial Force	F_{2aB}	N	8,200
額定壽命 / Rated Life	L_H	hr	S5 周期運轉 : >6,000 (S1 連續運轉 : >3,000 hrs) S5 Cycle Operation: >6,000 (S1 Continuous Operation: >3,000 hrs)
扭轉剛性 / Torsional Rigidity		Nm/arcmin	150
效率 / Efficiency	η	%	≥ 85
全合成潤滑油脂 / Synthetic Grease		g	480
重量 / Weight		kg	18.86

MODEL : RCN110

RATIO : 66、99、132

Unit: mm

Model Code	RCN110
A1	115、145、165
A2	M6、M8、M10
A3	95、110、130
A4	122、130、150
A5	24、28
A6	27.3、31.3

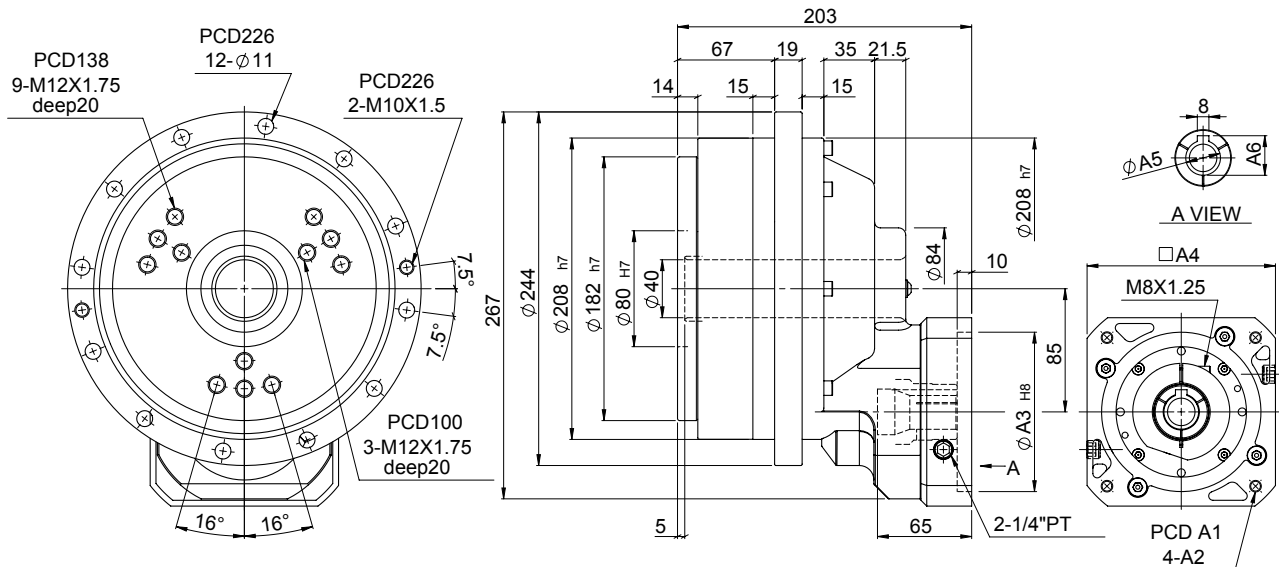

特性 Characteristic	代號	單位 Unit	RCN110
輸出平台支撐軸承 / Output Table Supporting Bearing			斜角滾珠軸承 Angular Contact Ball Bearing
額定輸出扭矩 / Rated Output Torque		Nm	1,100
最大輸出扭矩 / Max. Output Torque 急停扭矩 / Emergency Stop Torque	T_{2NOT}	Nm	5 倍額定輸出扭矩 5 Time of Rated Output Torque
最大加速力矩 / Max. Acceleration Torque	T_{2B}	Nm	2.5 倍額定輸出力矩 2.5 Times of Rated Output Torque
慣性慣量 / Inertia Moment		kg.m ²	15 x 10 ⁻⁴
額定出力轉速 / Rated Output Speed		rpm	15
最大輸出轉速 / Max. Output Speed		rpm	35
容許輸入轉速 / Permissible Input Speed		rpm	3,000
背隙 / Backlash Ps	J_t	arcmin	≤ 1
背隙 / Backlash P0	J_t	arcmin	≤ 3
背隙 / Backlash P1	J_t	arcmin	≤ 5
容許徑向力 / Max. Radial Force	F_{2rB}	N	16,000
容許軸向力 / Max. Axial Force	F_{2aB}	N	12,000
額定壽命 / Rated Life	L_H	hr	S5 周期運轉 : >6,000 (S1 連續運轉 : >3,000 hrs) S5 Cycle Operation: >6,000 (S1 Continuous Operation: >3,000 hrs)
扭轉剛性 / Torsional Rigidity		Nm/arcmin	210
效率 / Efficiency	η	%	≥ 85
全合成潤滑油脂 / Synthetic Grease		g	710
重量 / Weight		kg	27.1

MODEL : RCN160

RATIO : 66、99、132

Unit: mm

Model Code	RCN160
A1	115、145、165
A2	M6、M8、M10
A3	95、110、130
A4	122、130、150
A5	28、32
A6	8、10
A7	31.3、35.3

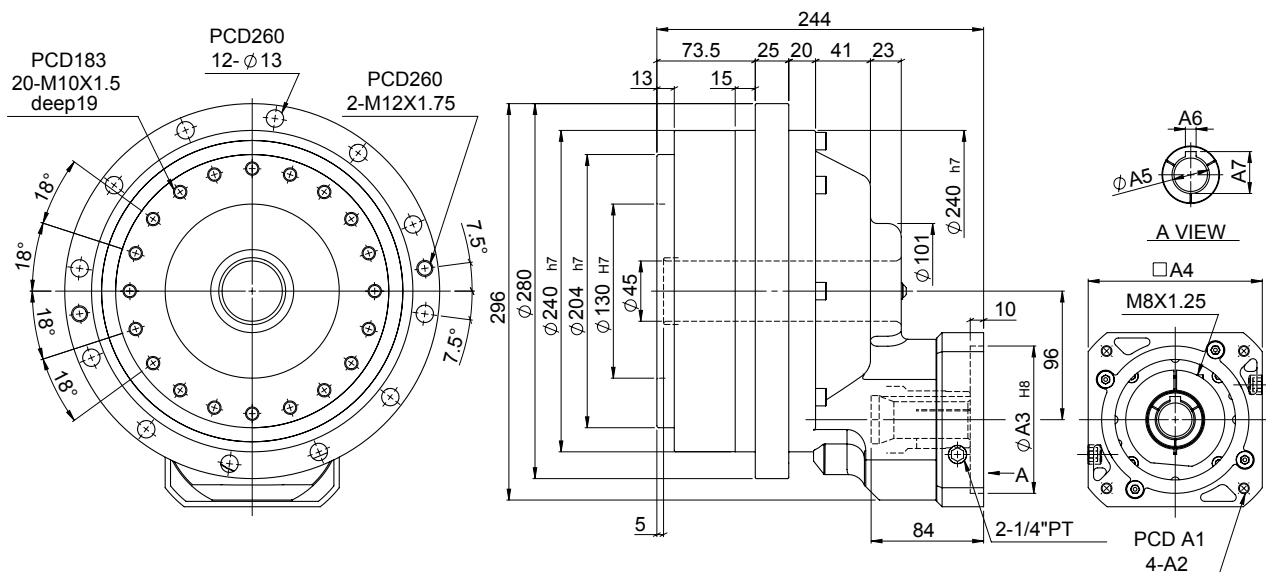

特性 Characteristic	代號	單位 Unit	RCN160
輸出平台支撐軸承 / Output Table Supporting Bearing			斜角滾珠軸承 Angular Contact Ball Bearing
額定輸出扭矩 / Rated Output Torque		Nm	1,600
最大輸出扭矩 / Max. Output Torque	T_{2NOT}	Nm	5 倍額定輸出扭矩 5 Time of Rated Output Torque
急停扭矩 / Emergency Stop Torque			
最大加速力矩 / Max. Acceleration Torque	T_{2B}	Nm	2.5 倍額定輸出力矩 2.5 Times of Rated Output Torque
慣性慣量 / Inertia Moment		kg.m ²	25 x 10 ⁻⁴
額定出力轉速 / Rated Output Speed		rpm	15
最大輸出轉速 / Max. Output Speed		rpm	27
容許輸入轉速 / Permissible Input Speed		rpm	3,000
背隙 / Backlash Ps	J_i	arcmin	≤ 1
背隙 / Backlash P0	J_i	arcmin	≤ 3
背隙 / Backlash P1	J_i	arcmin	≤ 5
容許徑向力 / Max. Radial Force	F_{2rB}	N	19,000
容許軸向力 / Max. Axial Force	F_{2aB}	N	15,000
額定壽命 / Rated Life	L_H	hr	S5 周期運轉 : >6,000 (S1 連續運轉 : >3,000 hrs) S5 Cycle Operation: >6,000 (S1 Continuous Operation: >3,000 hrs)
扭轉剛性 / Torsional Rigidity		Nm/arcmin	300
效率 / Efficiency	η	%	≥ 85
全合成潤滑油脂 / Synthetic Grease		g	800
重量 / Weight		kg	36.9

MODEL : RCN320

RATIO : 82、123、164

Unit: mm

Model Code	RCN320
A1	145、165、200
A2	M8、M10、M12
A3	110、130、180
A4	146、150、190
A5	32、35
A6	35.3、38.3

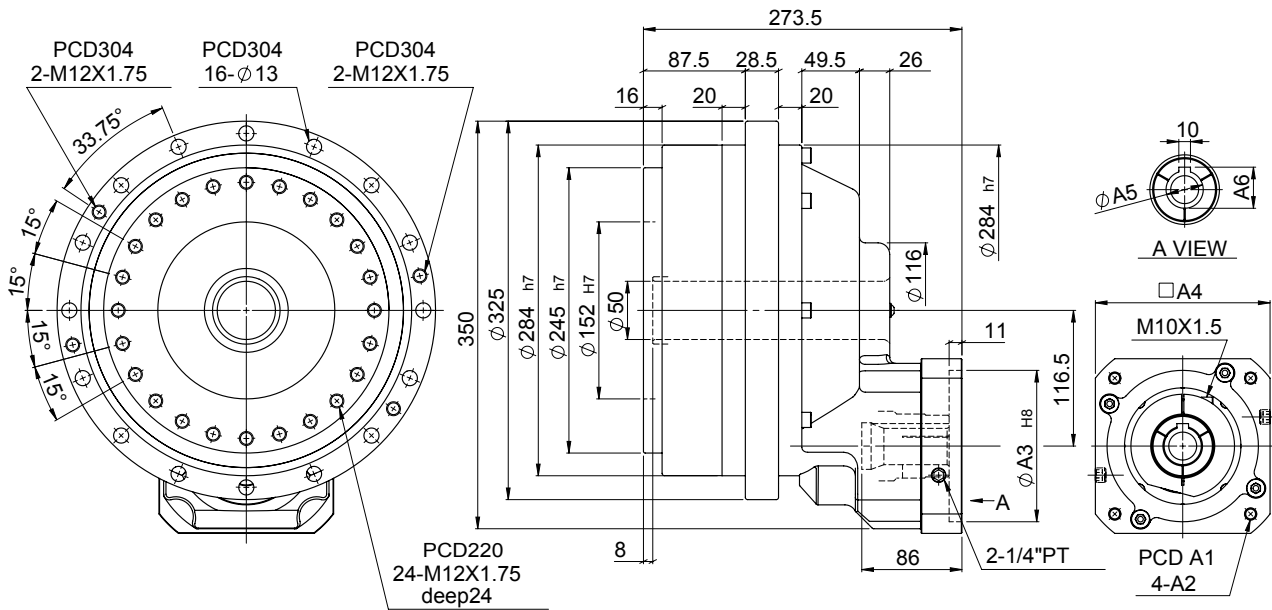

特性 Characteristic	代號	單位 Unit	RCN320
輸出平台支撐軸承 / Output Table Supporting Bearing			斜角滾珠軸承 Angular Contact Ball Bearing
額定輸出扭矩 / Rated Output Torque		Nm	3,200
最大輸出扭矩 / Max. Output Torque 急停扭矩 / Emergency Stop Torque	T_{2NOT}	Nm	5 倍額定輸出扭矩 5 Time of Rated Output Torque
最大加速力矩 / Max. Acceleration Torque	T_{2B}	Nm	2.5 倍額定輸出力矩 2.5 Times of Rated Output Torque
慣性慣量 / Inertia Moment		kg.m ²	32 x 10 ⁻⁴
額定出力轉速 / Rated Output Speed		rpm	15
最大輸出轉速 / Max. Output Speed		rpm	21
容許輸入轉速 / Permissible Input Speed		rpm	3,000
背隙 / Backlash Ps	J_i	arcmin	≤ 1
背隙 / Backlash P0	J_i	arcmin	≤ 3
背隙 / Backlash P1	J_i	arcmin	≤ 5
容許徑向力 / Max. Radial Force	F_{2rB}	N	25,300
容許軸向力 / Max. Axial Force	F_{2aB}	N	20,000
額定壽命 / Rated Life	L_H	hr	S5 周期運轉 : >6,000 (S1 連續運轉 : >3,000 hrs) S5 Cycle Operation: >6,000 (S1 Continuous Operation: >3,000 hrs)
扭轉剛性 / Torsional Rigidity		Nm/arcmin	980
效率 / Efficiency	η	%	≥ 85
全合成潤滑油脂 / Synthetic Grease		g	1,700
重量 / Weight		kg	63.9

軸套 Bushing

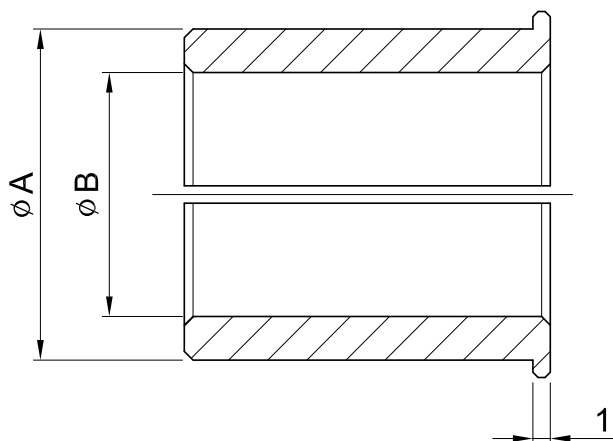

軸套內徑為所使用伺服馬達的輸出軸軸徑。
下表中沒有的情況下需要插入軸套，在您所使用的輸出軸軸徑的近似值中選擇大值。

連接軸_孔徑 Shaft Bore ØB 軸套_孔徑 Bushing Bore ØA	8	11	14	19	22	24	28	32	35
6	●	●							
6.35	●								
8		●							
9		●							
10			●						
11			●						
12			●						
12.7			●						
14				●					
15.85				●					
16				●		●	●		
19					●	●	●		
22						●	●	●	
24							●		●
28								●	●
32									●

高精度擺線減速機與馬達安裝指南 CYKODRIVE and Motor Mounting Instructions



1

核對馬達型號與減速機規格是否正確。
並將配合面擦拭乾淨。
Confirm the motor, and gearbox size.
Clean up the mounting surface.



2

如馬達軸徑在 $\varnothing 35$ 以下，請將馬達軸上的鍵拿掉。
Remove the motor key if the diameter of motor shaft is under $\varnothing 35$.

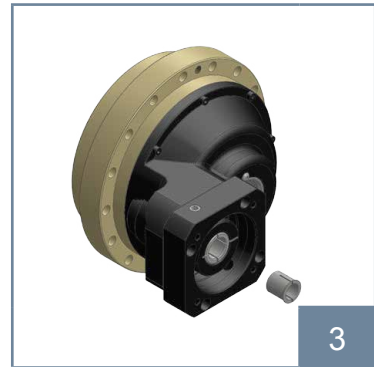

3

檢查馬達出力軸尺寸，如需軸套，請先裝進入力孔內。
Check motor shaft size and insert bushing into input bore if necessary.

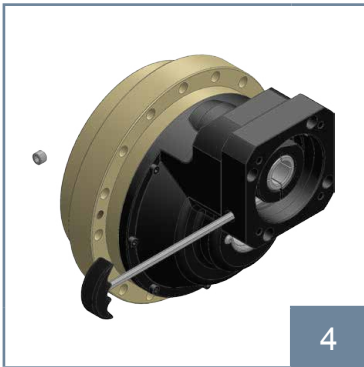

4

取出塞頭，使用六角板手將迫緊環螺絲鬆開。並將螺絲對準孔位。
Remove the plug on the adapter plate. Rotate the set collar till the bolt is line up.

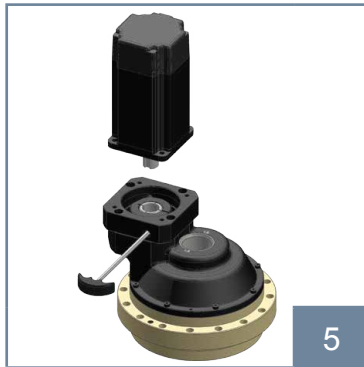

5

將馬達垂直裝入減速機。
Put the motor into the gearbox vertically.

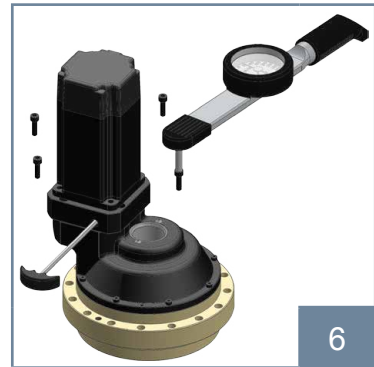

6

依序使用扭力板手鎖上外六角螺絲。
Tighten the mounting bolt in 1~4 order with torque wrench.

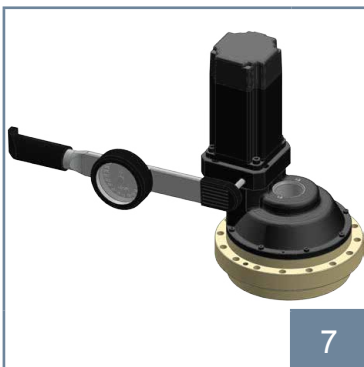

7

使用扭力板手將迫緊環螺絲鎖緊。
Tighten the set collar bolt with torque wrench.



8

裝回塞頭。
Tighten back the screw plug.

1. 務必先鎖緊馬達，才能鎖緊馬達軸心迫緊環。
To be sure to tighten motor first and then to tighten the set collar on motor shaft.
2. 請依步驟順序組裝，尤其步驟 6、7 不可顛倒。
Please assembly in order according to above steps, especially for step 6 and step 7.

